

PRODUCT SPECIFICATION DRAWING

QUICK STAND™ #30-SWHP-M

Suspended Equipment Platform

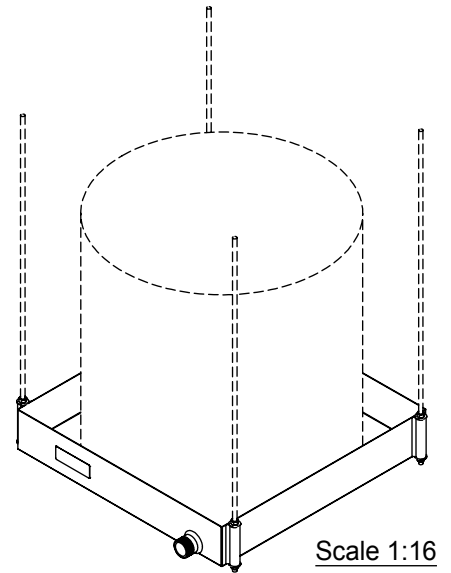
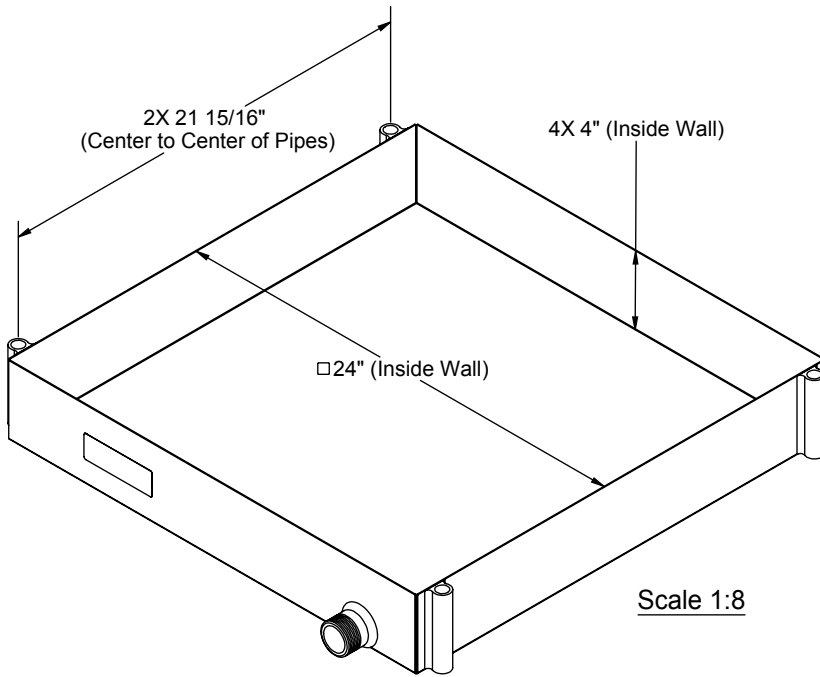

ALL DIMENSIONS IN INCHES

The #30-SWHP-M Suspended Equipment Platform is engineered to support equipment up to 300 pounds (such as a 20 U.S. gallon water heater or other equipment). This time and labor savings tool is designed for the Professional Contractor. Design features requested by plumbers are incorporated into a professional platform and drain pan combination that can be suspended with 3/8" or 1/2" all thread rods.

Product Information:

- Material:
 - Pan: 18 gage CRS, galvanized
 - Hanger Support Sleeves: CRS, galvanized Pipe, 5/8" I.D. x 7/8" O.D x 4" Long
 - Drain Nipple: Schedule 40 galvanized steel with MIP threads, 1-1/4" I.D.
- Wide platform allows water heaters up to 23-3/4" diameter
- Watertight welded corners and welded 1-1/4" I.D. steel drain body eliminate need for additional drain pan
- Static load rating 300 pounds with 2X safety factor (depending on structural anchorage)
- Galvanized steel construction
- Suspends with user supplied 3/8" or 1/2" threaded rod and hardware
- Four attachment points allows for seismic/sway bracing connection
- Patent pending

Product Submittal	
Job Name:	
Date:	
Part Number:	Qty:
Architect / Owner:	
Contractor:	
Notes:	

