

PRODUCT SPECIFICATION DRAWING

QUICKSTAND™ 21-1/2" X 21-1/2" (Water Heater & Equipment Support)

#40-S-22-A (assembled) and #40-S-22-U (unassembled)

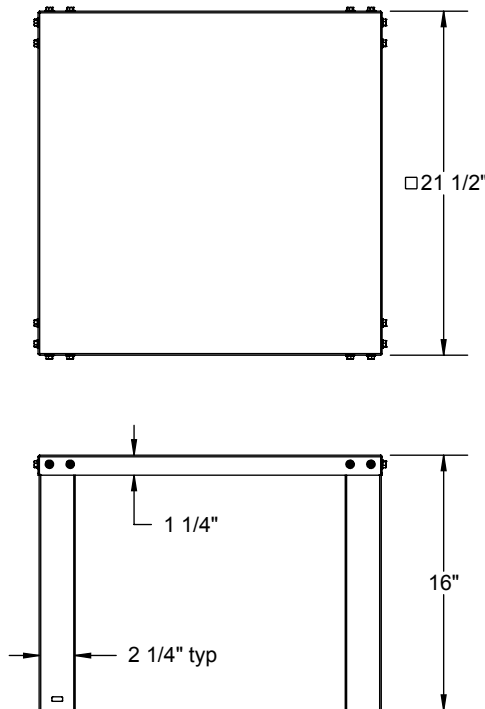
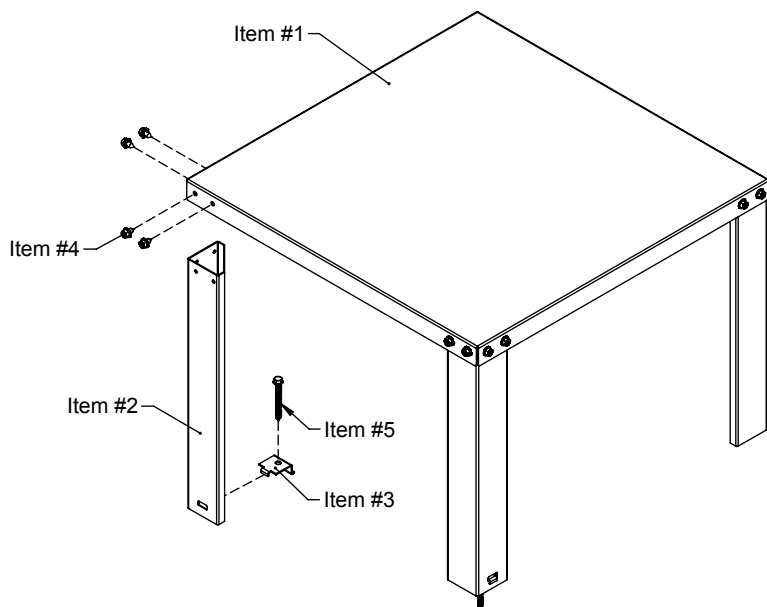

The QUICKSTAND™ #40-S-22- (A or U) stands safely elevates water heaters and other equipment above the floor (650 lbs rating).

ALL DIMENSIONS IN INCHES

Product Information:

- Material:
 - Item #1: Top, 16 gage CRS, galvanized
 - Item #2: Leg, 16 gage CRS, galvanized, 4 places
 - Item #3: Safety Clip, 14 gage CRS, galvanized, 2 places
 - Item #4: Screw, Php, HexWasherHd, #1/4-14 x 1/2"L (serrated), 16 places
 - Item #5: Lag Bolt, #1/4 X 2-1/2"L, self-drilling, 2 places
 - (note: items #3 and #5 included with product)
- Engineered and lab tested to meet Uniform Plumbing Code (UPC) and International Plumbing Code (IPC) requirements, including elevation of water heater's ignition source 18" above the floor
- Holds up to 650 pounds capacity (up to 52 U.S. gallon tanks)
- QUICKSTAND™ weight 15 pounds without packaging
- Available in assembled and unassembled configurations



Product Submittal	
Job Name:	
Date:	
Part Number:	Qty:
Architect / Owner:	
Contractor:	
Notes:	

.....HUBBARD ENTERPRISES.....
HOLDRITE®
 "Converting Makeshift Methods into Engineered Solutions"™