

PRODUCT SPECIFICATION DRAWING

QUICK STAND™ #40-SWHP-WM

Wall Mounted Equipment Platform

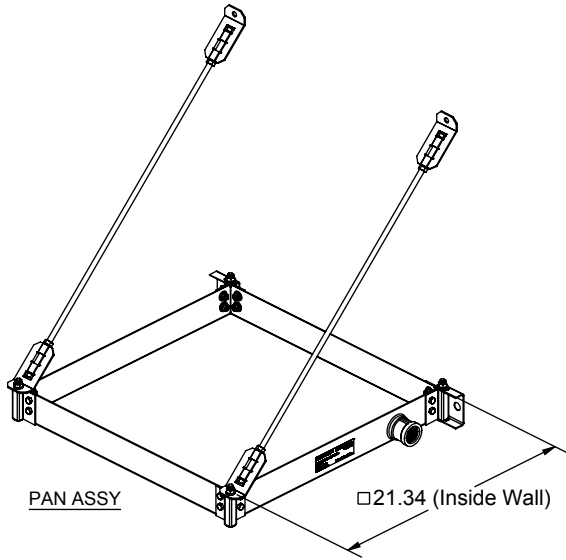

ALL DIMENSIONS IN INCHES

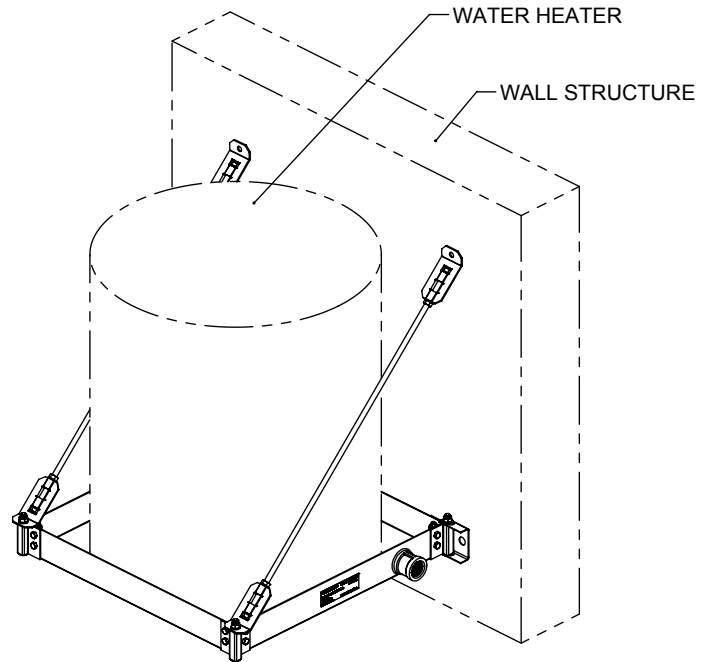

The Wall Mounted Equipment Platform is engineered to support water heaters up to 20 U.S. gallons (or other equipment up to 375 pounds total weight) mounted to a wall. This item also serves as a drain pan.

Product Information:

- Material:
 - Pan: 14 gage CRS, galvanized
 - Corner Brackets (4): 14 gage CRS, galvanized
 - C-Brackets (2): 16 gage CRS, galvanized
 - 45° Brackets (4): 12 gage, CRS, galvanized
 - Threaded Rod (2): Low carbon steel, zinc plated, 3/8" x 29-3/4" long
- Wide platform allows water heaters up to 21-1/4" diameter
- Watertight corners and welded 1" steel drain body eliminate need for additional drain pan
- Static load rating 375 pounds with 2X safety factor (depending on structural anchorage)
- Professional Engineer stamped documentation available
- Galvanized steel construction
- Suspends with user supplied 3/8" hardware to mount to wall, 4 places
- Installation instructions for mounting to concrete or framed wall structure available
- Patent Pending

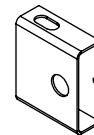

"C" Bracket, 2 places

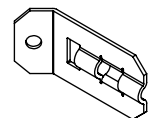

45° Bracket, 4 places

Product Submittal	
Job Name:	
Date:	
Part Number:	Qty:
Architect / Owner:	
Contractor:	
Notes:	

