

# PRODUCT SPECIFICATION DRAWING

## QUICK BELT™ #QB-50-F

### Seismic support for water heaters

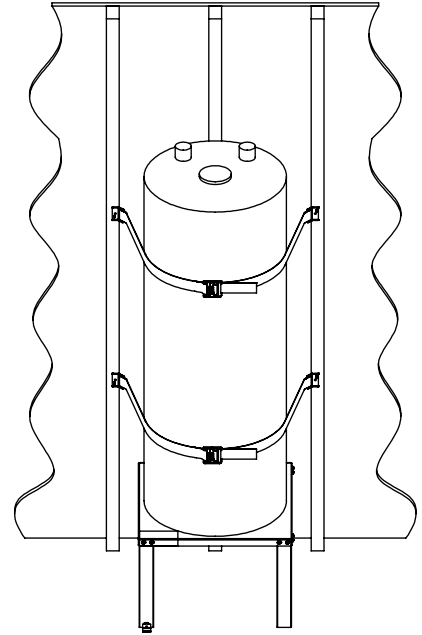
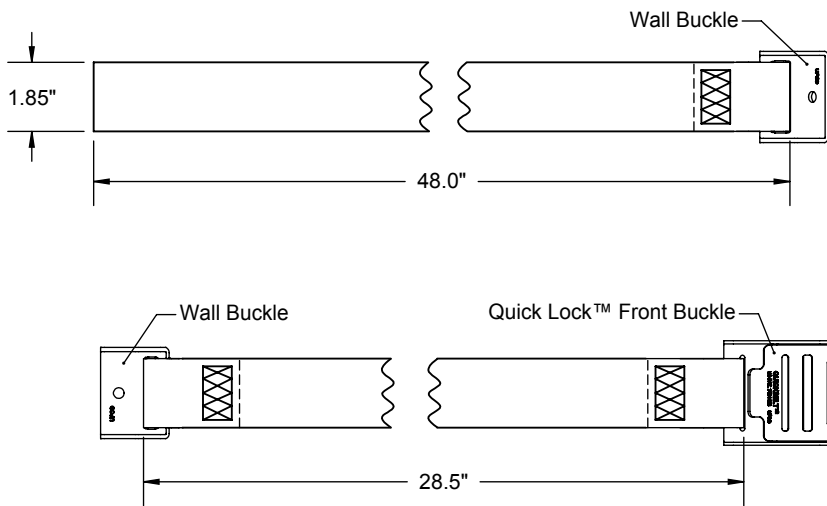

Lag Bolt, #1/4-10 x 2-1/2" Long

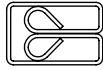

Belt Clip

ALL DIMENSIONS IN INCHES

**The QUICK BELT™ #QB-50-F is a seismic/earthquake support system for water heaters up to 80 U.S. gallons in size. The system includes: (4) Straps, (4) Lag Bolts and (2) Belt Clips. The Quick Lock™ system allows for secure locking of the strap from the front side of the water heater.**

#### Product Information:

- Material:  
 Wall Buckles: 12 gage CRS, galvanized  
 Front Buckle: 14 gage CRS, galvanized  
 Strap: Polyester, medium gray
- Approval: DSA #002-04
- U.S. Patent 7461435
- UPC / IPC / IAPMO listed

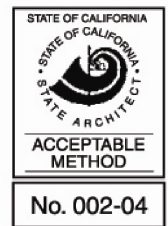

Product Submittal	
Job Name:	
Date:	
Part Number:	Qty:
Architect / Owner:	
Contractor:	
Notes:	

.....HUBBARD ENTERPRISES.....  
**HOLDRITE®**  
 "Converting Makeshift Methods into Engineered Solutions"™