

# PRODUCT SPECIFICATION DRAWING QUICKSTRAP® #QSS (Water Heater Spacer)

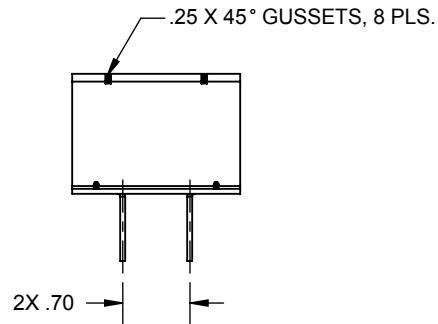
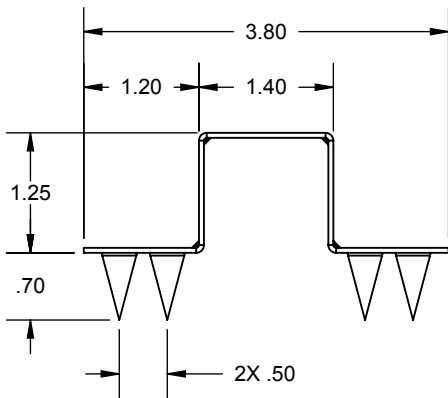
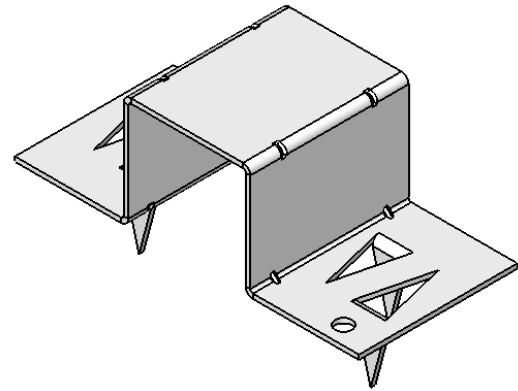
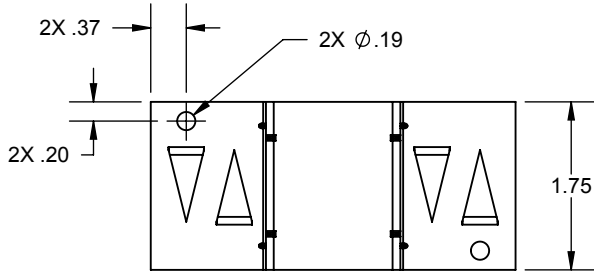

ALL DIMENSIONS IN INCHES

The QUICKSTRAP® #QSS water heater spacer provides a 1-1/4" space between the water heater and the adjacent wall. Typically used for non "zero clearance" installations.

### Product Information:

- Material: 18 gage CRS, galvanized

THIS INFORMATION IS PROPRIETARY TO HUBBARD ENTERPRISES AND IS SUBJECT TO CHANGE WITHOUT NOTICE. ANY REPRODUCTION IN PART OR WHOLE WITHOUT THE WRITTEN PERMISSION OF HUBBARD ENTERPRISES IS PROHIBITED.

**.....HUBBARD ENTERPRISES.....**  
***HOLDRITE***®  
*"Converting Makeshift Methods into Engineered Solutions"*

Product Submittal	
Job Name:	
Date:	
Part Number:	Qty:
Architect / Owner:	
Contractor:	
Notes:	