

Table of Contents

Electrical Firestop Submittal non-metallic penetrations in wood frame construction (HydroFlame 100)

UL System Number	Wall or Floor Type	System Description	Holdrite Firestop Product
F-C-2489	wood floor / ceiling	1 hour. L Rating. Chase wall. Max 3" rigid non-metallic conduit, max 3" electrical nonmetallic tubing.	HF 100, HF 200
F-C-3122	wood floor/ceiling	1 or 2 hour. L Rating. Optional chase wall. Cable bundle (various) Max diameter of bundle not to exceed 3-1/2"	HF 100
F-C-3123	wood floor/ceiling	1 hour. Optional chase wall. Cable bundle (various). Max diameter of bundle 3"	HF 100
F-C-8057	wood floor/ceiling	1 hour. Optional chase wall. Multiple penetration: Max 2" steel, iron, copper pipe/tubing, PVC, CPVC, RNC, or 1" PEX. Cable bundle SER, ROMEX, fiber optic, MC cables, various others	HF 100, HF 200
W-L-2716	Gypsum Wall	1 or 2 hour. L Rating. Max 2" rigid non metallic conduit	HF 100
W-L-2717	Gypsum Wall	1 or 2 hour. Max 2" Electrical non metallic tubing (ENT)	HF 100
W-L-3455	Gypsum Wall	1 or 2 hour. Optional steel sleeve. Sleeve can extend 1" from wall surface. Cable bundle (various)	HF 100, HF 200
W-L-3457	Gypsum Wall	1 or 2 hour. Membrane penetration. Max 3 metal clad cables with PVC jackets tightly bundled together.	HF 100, HF 200
W-L-3458	Gypsum Wall	1 or 2 hour. Membrane penetration. Sleeved opening extending max 12" from wall surface. Cable bundle (various)	HF 100, HF 200
W-L-7291	Gypsum Wall	1 or 2 hour. Max 1-5/8" x 1-5/8" channel strut, max 3-14" x 1-5/8" H strut, max 3/8" cable, or max 5/8" threaded rod mechanical support	HF 100, HF 200
W-L-8119	Gypsum Wall	1 or 2 hour. Max 4" steel, cast iron, conduit, copper pipe or tubing. Various cables/bundles	HF 100

XHEZ.F-C-2489 - THROUGH-PENETRATION FIRESTOP SYSTEMS

Design/System/Construction/Assembly Usage Disclaimer

- Authorities Having Jurisdiction should be consulted in all cases as to the particular requirements covering the installation and use of UL Certified products, equipment, system, devices, and materials.
- Authorities Having Jurisdiction should be consulted before construction.
- Fire resistance assemblies and products are developed by the design submitter and have been investigated by UL for compliance with applicable requirements. The published information cannot always address every construction nuance encountered in the field.
- When field issues arise, it is recommended the first contact for assistance be the technical service staff provided by the product manufacturer noted for the design. Users of fire resistance assemblies are advised to consult the general Guide Information for each product category and each group of assemblies. The Guide Information includes specifics concerning alternate materials and alternate methods of construction.
- Only products which bear UL's Mark are considered Certified.

XHEZ - Through-penetration Firestop Systems XHEZ7 - Through-penetration Firestop Systems Certified for Canada

See General Information for Through-penetration Firestop Systems

See General Information for Through-penetration Firestop Systems Certified for Canada

System No. F-C-2489

June 03, 2019

ANSI/UL1479 (ASTM E814)	CAN/ULC S115
F Rating — 1 Hr	F Rating — 1 Hr
T Ratings — 3/4 and 1 Hr (See Item 3)	FT Ratings — 3/4 and 1 Hr (See Item 3)
L Rating at Ambient — Less Than 1 CFM/sq ft	FH Rating — 1 Hr
L Rating at 400°F — Less Than 1 CFM/sq ft	FTH Ratings — 3/4 and 1 Hr (See Item 3)
	L Rating at Ambient — Less Than 5.1 L/s/m ²
	L Rating at 204°C — Less Than 5.1 L/s/m ²

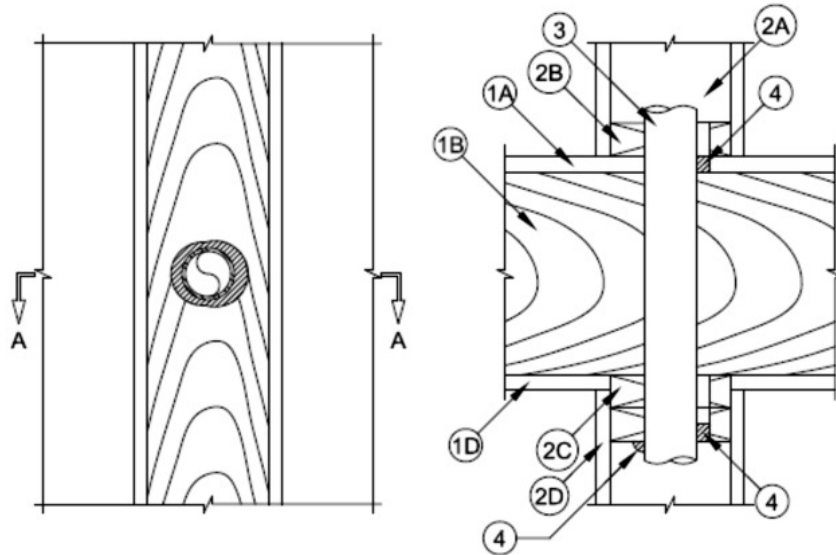

1. **Floor — Ceiling Assembly** — The 1 hr fire-rated wood joist floor-ceiling assembly shall be constructed of the materials and in the manner specified in the individual L500 Designs in the UL Fire Resistance Directory, as summarized below:

A. **Flooring System** — Lumber or plywood subfloor with finish floor of lumber, plywood or **Floor Topping Mixture*** as specified in the individual Floor-Ceiling Design. Max diam of floor opening is 4 in. (102 mm).

B. **Wood Joists** — Nom 10 in. (254 mm) deep (or deeper) lumber, steel or combination lumber and steel joists, trusses or **Structural Wood Members*** with bridging as required and with ends firestopped.

C. **Gypsum Board*** — Nom 5/8 in. (16 mm) thick as specified in the individual Floor-Ceiling Design. Wallboard secured to joists as specified in the individual Floor-Ceiling Design.

2. **Chase Wall** — The through penetrant (Item No. 3) shall be routed through wood stud/gypsum board chase wall and shall include the following construction features:

A. **Studs** — Nom 2 by 6 in. (51 by 152 mm) lumber studs.

B. **Sole Plate** — Nom 2 by 6 in. (51 by 152 mm) lumber plates. Diam of opening or length of notch-out in sole plate to be 1/2 in. (13 mm) larger than outside diam of pipe.

C. **Top Plate** — The double top plate shall consist of two nom 2 by 6 in. (51 by 152 mm) lumber plates. Diam of opening or length of notch-out in top plate to be 1/2 in. (13 mm) larger than outside diam of pipe.

D. **Gypsum Board** — Min 1/2 in. (13 mm) thick rated or nonrated gypsum board.

2A. **Alternate Chase Wall** — (Not Shown) — For nom 2 in. diam (or smaller) through penetrants (Item No. 3), the pipes may be routed through wood stud/gypsum board chase wall as an alternate to Item 2 and shall include the following construction features:

A. **Studs** — Nom 2 by 4 in. (51 by 102 mm) lumber studs.

B. **Sole Plate** — Nom 2 by 4 in. (51 by 102 mm) lumber plates. Diam of opening or length of notch-out in sole plate to be 1/2 in. (13 mm) larger than outside diam of pipe.

C. **Top Plate** — The double top plate shall consist of two nom 2 by 4 in. (51 by 102 mm) lumber plates. Diam of opening or length of notch-out in top plate to be 1/2 in. (13 mm) larger than outside diam of pipe.

D. **Gypsum Board** — Min 1/2 in. (13 mm) thick rated or nonrated gypsum board.

3. **Through Penetrants** — One nonmetallic pipe to be centered within the firestop system. The annular space between pipe and periphery of opening shall be 0 in. (point contact) to 1/2 in. (13 mm) Pipe to be rigidly supported on both sides of floor assembly. The following types and sizes of nonmetallic pipes may be used:

A. **Polyvinyl Chloride (PVC) Pipe** — Nom 3 in. (76 mm) Schedule 40 solid core PVC pipe for use in closed (process or supply) or vented (drain, waste or vent) piping systems. **T Rating is 1 h.**

B. **Chlorinated Polyvinyl Chloride (CPVC) Pipe** — Nom 3 in. (76 mm) diam (or smaller) SDR 13.5 CPVC pipe for use in closed (process or supply) piping systems. **T Rating is 1 h.**

C. **Rigid Non-Metallic Conduit +** — Nom 3 in. (76 mm) Diam (or smaller) PVC conduit installed in accordance with the National Electrical Code (NFPA 70). **T Rating is 1 h.**

D. **Electrical Nonmetallic Tubing+** — Nom 3 in. (76 mm) (or smaller) PVC tubing installed in accordance with the National Electrical Code (NFPA 70). **T Rating is 1 h.**

E. **Crosslinked Polyethylene (PEX) tubing** — Nom 1-1/2 in. (38 mm) diam (or smaller) SDR 9 tube used for closed (process or supply) or vented (drain, waste or vent) piping systems, with HydroFlame 200 (Item 4A). **T Rating is 3/4 h.**

F. **Chlorinated Polyvinyl Chloride (CPVC) Pipe** — Nom. 2 in. (51 mm) diam (or smaller) Blazemaster® SDR 13.5 CPVC pipe for use in closed (process or supply) piping systems. **T Rating is 1 h.**

G. **Polypropylene (PP) Pipe** — Nom 2 in. (51 mm) diam (or smaller) Aquatherm Greenpipe SDR 11 PP pipe for use in closed (process or supply) piping systems, with HydroFlame 200 (Item 4A). Maximum total annular space shall be 1/2 in. with no point contact. **T Rating is 1 hr.**

4. **Firestop System** — The firestop system shall consist of the following:

A. **Fill, Void or Cavity Material* — Caulk** — Min 3/4 in. (19 mm) thickness of fill material applied within annulus, flush with top surface of floor. Min 3/4 in. (19 mm) thickness of fill material applied within annulus, flush with bottom surface of top plate. Min 1/2 in. (13 mm) crown bead at point contact.

RELIANCE WORLDWIDE CORPORATION DBA HOLDRITE HYDROFLAME — HydroFlame 200 or HydroFlame 100

*** Indicates such products shall bear the UL or cUL Certification Mark for jurisdictions employing the UL or cUL Certification (such as Canada), respectively.**

+Bearing the UL Listing Mark

Last Updated on 2019-06-03

The appearance of a company's name or product in this database does not in itself assure that products so identified have been manufactured under UL's Follow-Up Service. Only those products bearing the UL Mark should be considered to be Certified and covered under UL's Follow-Up Service. Always look for the Mark on the product.

UL permits the reproduction of the material contained in the Online Certification Directory subject to the following conditions: 1. The Guide Information, Assemblies, Constructions, Designs, Systems, and/or Certifications (files) must be presented in their entirety and in a non-misleading manner, without any manipulation of the data (or drawings). 2. The statement "Reprinted from the Online Certifications Directory with permission from UL" must appear adjacent to the extracted material. In addition, the reprinted material must include a copyright notice in the following format: "© 2019 UL LLC"

XHEZ.F-C-3122 - THROUGH-PENETRATION FIRESTOP SYSTEMS

Design/System/Construction/Assembly Usage Disclaimer

- Authorities Having Jurisdiction should be consulted in all cases as to the particular requirements covering the installation and use of UL Certified products, equipment, system, devices, and materials.
- Authorities Having Jurisdiction should be consulted before construction.
- Fire resistance assemblies and products are developed by the design submitter and have been investigated by UL for compliance with applicable requirements. The published information cannot always address every construction nuance encountered in the field.
- When field issues arise, it is recommended the first contact for assistance be the technical service staff provided by the product manufacturer noted for the design. Users of fire resistance assemblies are advised to consult the general Guide Information for each product category and each group of assemblies. The Guide Information includes specifics concerning alternate materials and alternate methods of construction.
- Only products which bear UL's Mark are considered Certified.

XHEZ - Through-penetration Firestop Systems XHEZ7 - Through-penetration Firestop Systems Certified for Canada

See General Information for Through-penetration Firestop Systems

See General Information for Through-penetration Firestop Systems Certified for Canada

System No. F-C-3122

January 29, 2019

ANSI/UL1479 (ASTM E814)	CAN/ULC S115
F Ratings - 1 and 2 Hr (See Item 1)	F Ratings - 1 and 2 Hr (See Item 1)
T Ratings - 0 Hr	FT Ratings - 0 Hr
	FH Ratings - 1 and 2 Hr (See Item 1)
	FTH Ratings - 0 Hr
L Rating At Ambient - Less Than 1 CFM/sq ft	L Rating At Ambient - Less Than 1 CFM/sq ft
L Rating At 400°F - 1.4 CFM/sq ft	L Rating At 400°F - 1.4 CFM/sq ft

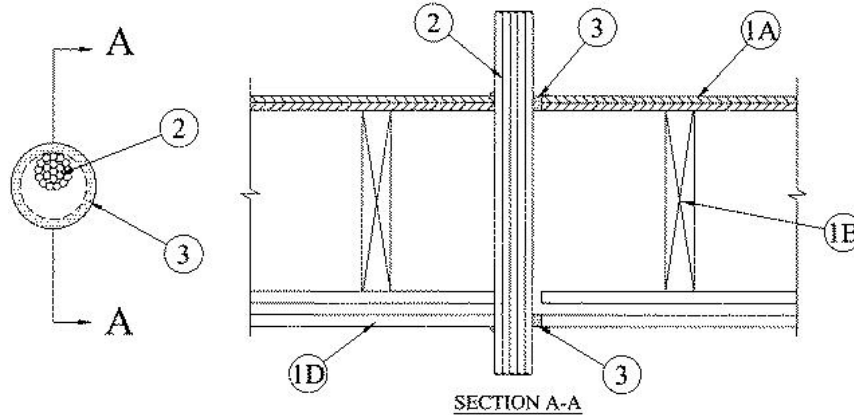

1. Floor Ceiling Assembly — The 1 hr fire-rated solid or trussed lumber joist floor-ceiling assembly shall be constructed of the materials and in the manner specified in the individual L500 Series Floor-Ceiling Designs in the UL Fire Resistance Directory. The 2 hr fire-rated wood joist floor-ceiling assembly shall be constructed of the materials and in the manner specified in Design Nos. L505, L511 or L536 in the UL Fire Resistance Directory. The general construction features of the floor-ceiling assembly are summarized below:

A. Flooring System — Lumber or plywood subfloor with finish floor of lumber, plywood or Floor Topping Mixture* as specified in the individual Floor-Ceiling Design. Max diam of floor opening is 4 in. (102 mm).

B. Wood Joists* — For 1 hr fire-rated floor-ceiling assemblies nom 10 in. (254 mm) deep (or deeper) lumber, steel or combination lumber and steel joists, trusses or Structural Wood Members* with bridging as required and with ends fireblocked. For 2 hr fire-rated floor-ceiling assemblies, nom 2 by 10 in. (51 by 254 mm) lumber joists spaced 16 in. (406 mm) OC with nom 1 by 3 in. (25 by 76 mm) lumber bridging and with ends fireblocked.

C. Furring Channels (Not Shown) — In 2 hr fire-rated assemblies, resilient galv steel furring installed perpendicular to wood joists between first and second layers of gypsum board (Item 1D). Furring channels spaced max 24 in. (610 mm) OC. In 1 hr fire-rated assemblies, resilient galv steel furring installed perpendicular to wood joists between gypsum board and wood joists as specified in the individual Floor-Ceiling Design. Furring channels spaced max 24 in. (610 mm) OC.

D. Gypsum Board* — Nom 4 ft (1.2 m) wide by 5/8 in. (16 mm) thick as specified in the individual Floor-Ceiling Design. First layer of gypsum board secured to wood joists or furring channels as specified in the individual Floor-Ceiling Design. Second layer of gypsum board (2 hr fire-rated assembly) screw-attached to furring channels as specified in the individual Floor-Ceiling Design. Max diam of ceiling opening is 4 in. (102 mm).

The F Rating of the firestop system is equal to the hourly fire rating of the floor-ceiling assembly in which it is installed.

1.1 Chase Wall — (Optional, Not Shown) — The through penetrants (Item 2) may be routed through a 1 or 2 hr fire-rated single, double or staggered wood stud/gypsum board chase wall having a fire rating consistent with that of the floor-ceiling assembly. The chase wall shall be constructed of the materials and in the manner specified in the individual U300 Series Wall and Partition Designs in the UL Fire Resistance Directory and shall include the following construction features:

A. **Studs** — Nom 2 by 6 in. (51 by 152 mm) lumber or double nom 2 by 4 in. (51 by 102 mm) lumber studs.

B. **Sole Plate** — Nom 2 by 6 in. (51 by 152 mm) lumber or parallel 2 by 4 in. (51 by 102 mm) lumber plates, tightly butted.

C. **Top Plate** — The double top plate shall consist of two nom 2 by 6 in. (51 by 152 mm) lumber plates or two sets of nom 2 by 4 in. (51 by 102 mm) lumber plates tightly butted. Max diam of opening is 4 in. (102 mm).

D. **Gypsum Board*** — Thickness, type, number or layers and fasteners shall be as specified in individual Wall and Partition Designs.

2. **Cables** — Max 3-1/2 in. (89 mm) diam bundle tight bundle of cables to be installed either concentrically or eccentrically within the firestop system. The annular space between cable bundle and the periphery of the opening shall be a min 0 in. (point contact) to max 1/2 in. (13 mm). Penetrants to be rigidly supported on both sides of floor-ceiling assembly. The following types and sizes of cables may be used:

A. Max 100 pair No. 24 AWG (or smaller) copper conductor telecommunication cable with PVC insulation and jacketing.

B. Max 3/C No. 2/0 AWG (or smaller) aluminum conductor SER cable with PVC insulation and jacketing.

C. Max 3/C with ground No. 12 AWG (or smaller) Type NM (Romex) nonmetallic sheathed cable with PVC insulation and jacketing.

D. Max 7/C No. 12 AWG (or smaller) power/control cables with PVC insulation and jacketing.

E. Max RG/U (or smaller) copper conductor coaxial cable with fluorinated ethylene insulation and jacketing materials.

2A. **Through Penetrating Products*** — Max 4/C with ground No. 2 AWG (or smaller) aluminum or copper conductor aluminum jacketed Metal-Clad+ cable. Max one cable to be installed within the cable bundle. Max diam of cable bundle including this metal clad cable not to exceed 3-1/2 in. (89 mm).

GENERAL CABLE INDUSTRIES INC

3. **Fill, Void or Cavity Material* — Sealant** — Min 3/4 in. (19 mm) thickness of fill material applied within the annulus, flush with the top surface of the floor or sole plate. Min 5/8 in. (16 mm) thickness of fill material applied within the annulus, flush with bottom surface of ceiling or top plate. Fill material to forced within interstices of cable bundle to max extent possible. At point contact, min 3/8 in. (10 mm) diam bead of fill material applied at cable bundle/floor or sole plate interface and at cable bundle/ceiling or top plate interface. Additional sealant shall be applied in such a manner that the sealant overlaps a min 1/2 in. (13 mm) beyond the periphery of the opening on the top surface of the floor or sole plate and bottom surface of ceiling or bottom top plate.

RELIANCE WORLDWIDE CORPORATION DBA HOLDRITE HYDROFLAME — HydroFlame 100

*** Indicates such products shall bear the UL or cUL Certification Mark for jurisdictions employing the UL or cUL Certification (such as Canada), respectively.**

+Bearing the UL Listing Mark

Last Updated on 2019-01-29

The appearance of a company's name or product in this database does not in itself assure that products so identified have been manufactured under UL's Follow-Up Service. Only those products bearing the UL Mark should be considered to be Certified and covered under UL's Follow-Up Service. Always look for the Mark on the product.

UL permits the reproduction of the material contained in the Online Certification Directory subject to the following conditions: 1. The Guide Information, Assemblies, Constructions, Designs, Systems, and/or Certifications (files) must be presented in their entirety and in a non-misleading manner, without any manipulation of the data (or drawings). 2. The statement "Reprinted from the Online Certifications Directory with permission from UL" must appear adjacent to the extracted material. In addition, the reprinted material must include a copyright notice in the following format: "© 2019 UL LLC"

XHEZ.F-C-3123 - THROUGH-PENETRATION FIRESTOP SYSTEMS

Design/System/Construction/Assembly Usage Disclaimer

- Authorities Having Jurisdiction should be consulted in all cases as to the particular requirements covering the installation and use of UL Certified products, equipment, system, devices, and materials.
- Authorities Having Jurisdiction should be consulted before construction.
- Fire resistance assemblies and products are developed by the design submitter and have been investigated by UL for compliance with applicable requirements. The published information cannot always address every construction nuance encountered in the field.
- When field issues arise, it is recommended the first contact for assistance be the technical service staff provided by the product manufacturer noted for the design. Users of fire resistance assemblies are advised to consult the general Guide Information for each product category and each group of assemblies. The Guide Information includes specifics concerning alternate materials and alternate methods of construction.
- Only products which bear UL's Mark are considered Certified.

XHEZ - Through-penetration Firestop Systems XHEZ7 - Through-penetration Firestop Systems Certified for Canada

See General Information for Through-penetration Firestop Systems

See General Information for Through-penetration Firestop Systems Certified for Canada

System No. F-C-3123

January 29, 2019

ANSI/UL1479 (ASTM E814)	CAN/ULC S115
F Rating - 1 Hr	F Rating -1 Hr
	FH Rating -1 Hr
T Rating - 1 Hr	FT Rating -1 Hr
	FTH Rating -1 Hr

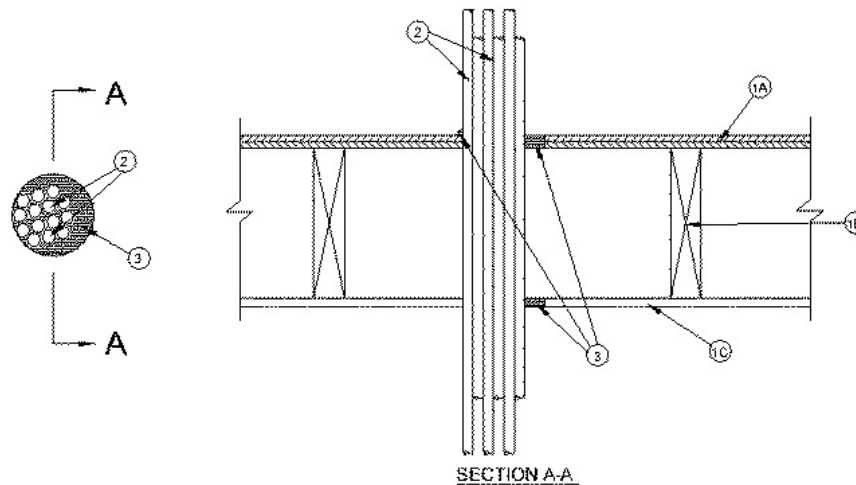

1. **Floor-Ceiling Assembly** — The 1 hr fire-rated wood joint floor ceiling assembly shall be constructed of the materials and in the manner specified in the individual L500 Designs in the UL Fire Resistance Directory, as summarized below:

A. **Flooring System** — Lumber or plywood subfloor with finish floor of lumber, plywood or **Floor Topping Mixture*** as specified in the individual Floor-Ceiling Design. Max diam of floor opening is 4-1/2 in. (114 mm)

B. **Wood Joists** — Nom 10 in. (254 mm) deep (or deeper) lumber, steel or combination lumber and steel joists, trusses or **Structural Wood Members*** with bridging as required and with ends firestopped.

C. **Gypsum Board*** — Nom 5/8 in. (16 mm) thick as specified in the individual Floor-Ceiling Design. Diam of opening to be max 1 in. (25 mm) larger than diam of bundled penetrants.

1A. **Chase Wall** — (Optional, Not Shown) — The through penetrants (Item 2) may be routed through a 1 hr fire-rated single, double or staggered wood stud/gypsum board chase wall. Depth of chase wall stud cavity to be min 1/2 in. (13 mm) greater than diameter of opening cut in sole and top plates to accommodate the through penetrant (Item 2). The chase wall shall be constructed of the materials and in the manner specified in the individual U300 Series Wall and Partition Designs in the UL Fire Resistance Directory and shall include the following construction features:

A. **Studs** — Nom 2 by 4 in. (51 by 102 mm), 2 by 6 in. (51 by 152 mm) or double nom 2 by 4 in. (51 by 102 mm) lumber studs.

B. **Sole Plate** — Nom 2 by 4 in. (51 by 102 mm), 2 by 6 in. (51 by 152 mm) or parallel 2 by 4 in. (51 by 102 mm) lumber plates, tightly butted. Max diam of opening is to be 1 in. (25 mm) larger than diam. of pipe.

C. **Top Plate** — The double top plate shall consist of two nom 2 by 4 in. (51 by 102 mm), two nom 2 by 6 in. (51 by 152 mm) or two sets of parallel 2 by 4 in. (51 by 102 mm) lumber plates, tightly butted. Max diam of opening is to be 1 in. (25 mm) larger than diam. of pipe.

D. **Gypsum Board*** — Thickness, type, number of layers and fasteners shall be as specified in the individual Wall and Partition Design.

2. **Cables** — Max 3 in. (76 mm) diam bundle of cables to be installed within the opening. At the plywood subfloor, bundled cables to be installed either concentrically or eccentrically within the opening with an annular space of min 0 in. (0 mm) (point contact) to max 1 in. (25 mm). At gypsum board ceiling, bundled cables to be installed either concentrically or eccentrically within the opening. Bundled cables to be rigidly supported on both sides of the floor-ceiling assembly. The following types and sizes of copper conductor cables shall be utilized in the opening:

- A. Max 750 MCM power cables; THHN or THWN jacketed.
- B. Max 8C, No.12 AWG multiconductor power and control cables; jacketed.
- C. Max 300 pair No. 24 AWG copper conductor communication cable with polyvinyl chloride insulation and jacket material.
- D. Max 25 pr/24 AWG telephone cable with polyethylene insulation and polyvinyl chloride jacket.
- E. Max 4/C No. 18 AWG (or smaller) thermostat cable with PVC insulation and jacket.
- F. Max 3C w/gnd, No. 12 AWG (or smaller) Romex NMC or SER w/pvc insulation and jacket.
- G. Max 3C w/gnd, 2/0 AWG, Type SER aluminum, polyvinyl insulation and jacket.
- H. Max 3C w/gnd, No. 6 AWG, Type NMC.

3. **Firestop System** — The firestop system shall consist of the following:

- A. **A. Fill, Void or Cavity Material* — Caulk** — Min 3/4 in. thickness of fill material applied within the annulus, flush with the top surface of the floor sole plate. Min 5/8 in. (16 mm) thickness of fill material applied within the annulus, flush with bottom surface of ceiling or top plate. Min 1/2 in. (13 mm) diam bead of fill material applied at point contact location on the top surface of floor or sole plate and at the penetrant/ceiling or top plate interface.
RELIANCE WORLDWIDE CORPORATION DBA HOLDRITE HYDROFLAME — HydroFlame 100

*** Indicates such products shall bear the UL or cUL Certification Mark for jurisdictions employing the UL or cUL Certification (such as Canada), respectively.**

+Bearing the UL Recognized Component Marking

Last Updated on 2019-01-29

The appearance of a company's name or product in this database does not in itself assure that products so identified have been manufactured under UL's Follow-Up Service. Only those products bearing the UL Mark should be considered to be Certified and covered under UL's Follow-Up Service. Always look for the Mark on the product.

UL permits the reproduction of the material contained in the Online Certification Directory subject to the following conditions: 1. The Guide Information, Assemblies, Constructions, Designs, Systems, and/or Certifications (files) must be presented in their entirety and in a non-misleading manner, without any manipulation of the data (or drawings). 2. The statement "Reprinted from the Online Certifications Directory with permission from UL" must appear adjacent to the extracted material. In addition, the reprinted material must include a copyright notice in the following format: "© 2019 UL LLC"

XHEZ.F-C-8057 - THROUGH-PENETRATION FIRESTOP SYSTEMS

Design/System/Construction/Assembly Usage Disclaimer

- Authorities Having Jurisdiction should be consulted in all cases as to the particular requirements covering the installation and use of UL Certified products, equipment, system, devices, and materials.
- Authorities Having Jurisdiction should be consulted before construction.
- Fire resistance assemblies and products are developed by the design submitter and have been investigated by UL for compliance with applicable requirements. The published information cannot always address every construction nuance encountered in the field.
- When field issues arise, it is recommended the first contact for assistance be the technical service staff provided by the product manufacturer noted for the design. Users of fire resistance assemblies are advised to consult the general Guide Information for each product category and each group of assemblies. The Guide Information includes specifics concerning alternate materials and alternate methods of construction.
- Only products which bear UL's Mark are considered Certified.

XHEZ - Through-penetration Firestop Systems

See General Information for Through-penetration Firestop Systems

System No. F-C-8057

January 29, 2019

F Rating — 1 Hr

T Rating - 1 Hr

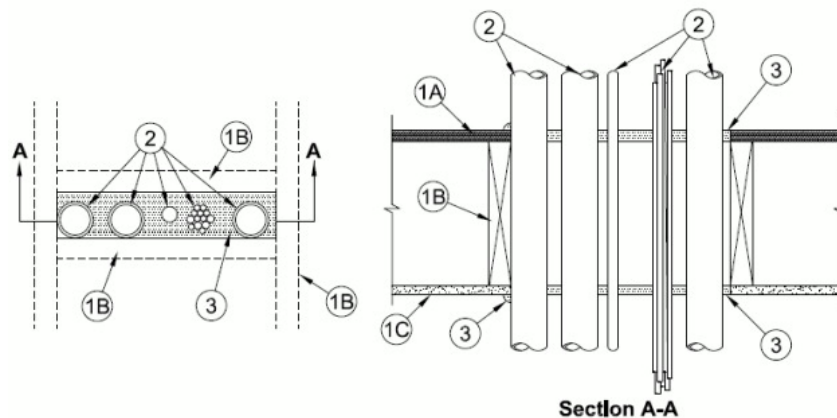

1. **Floor-Ceiling Assembly** — The 1 hr fire-rated wood joist floor-ceiling assembly shall be constructed of the materials and in the manner specified in the individual L500 Designs in the UL Fire Resistance Directory, as summarized below:

A. **Flooring System** — Lumber or plywood subfloor with finish floor of lumber, plywood or **Floor Topping Mixture*** as specified in the individual Floor-Ceiling Design. Max area of rectangular opening cut in flooring is 43-1/2 sq in. (0.028 m²) with a max width dimension of 3 in. (76 mm) and with a max length dimension of 14-1/2 in. (368 mm). Longer dimension of rectangular opening to be perpendicular to wood joist direction.

B. **Wood Joists** — Nom 2 by 10 in. (51 by 254 mm) lumber joist spaced max 16 in. (406 mm) OC with bridging as required and with ends firestopped. Opening to be framed with 2 by 10 in. (51 by 254 mm) lumber perpendicular to the joists.

C. **Gypsum Board*** — Thickness, type, number of layers and fasteners as required in the individual Floor-Ceiling Design. Max area of rectangular opening cut in gypsum board ceiling is 43-1/2 sq in. (0.028 m²) with a max width dimension of 3 in. (76 mm) and with a max length dimension of 14-1/2 in. (368 mm).

1A. **Chase Wall** — (Optional, Not Shown) - The through penetrants (Item 2) may be routed through a 1 hr fire rated single, double or staggered wood stud/gypsum board chase wall. Depth of chase wall stud cavity to be min 1/2 in. (13 mm) greater than width of opening cut in sole and top plates to accommodate the through penetrants. The chase wall shall be constructed of the materials and in the manner specified in the individual U300 Series Wall and Partition Designs in the UL Fire Resistance Directory and shall include the following construction features:

A. **Studs** — Nom 2 by 4 in. (51 by 102 mm), 2 by 6 in. (51 by 152 mm) or double nom 2 by 4 in. (51 by 102 mm) lumber studs.

B. **Sole Plate** — Nom 2 by 4 in. (51 by 102 mm), 2 by 6 in. (51 by 152 mm) or parallel 2 by 4 in. (51 by 102 mm) lumber plates, tightly butted. Max area of rectangular opening cut in sole plate is 43-1/2 sq in. (0.028 m²) with a max width dimension of 3 in. (76 mm) and with a max length dimension of 14-1/2 in. (368 mm).

C. **Top Plate** — The double top plate shall consist of two nom 2 by 4 in. (51 by 102 mm), two nom 2 by 6 in. (51 by 152 mm) or two sets of parallel 2 by 4 in. (51 by 102 mm) lumber plates, tightly butted. Max area of rectangular opening cut in top plate is 43-1/2 sq in. (0.028 m²) with a max width dimension of 3 in. (76 mm) and with a max length dimension of 14-1/2 in. (368 mm).

D. **Gypsum Board*** — Thickness, type, number of layers and fasteners shall be as specified in the individual Wall and Partition Design.

2. **Through Penetrants** — One or more metallic or nonmetallic pipes, conduits, tubing or cables to be installed either concentrically or eccentrically within the opening. Min separation between penetrants to be 1 in. (25 mm). Annular space between the penetrants and the periphery of the opening shall be min 0 in. (point contact) to max 1 in. (25 mm). Penetrants to be rigidly supported on both sides of floor-ceiling assembly. The following types and sizes of through penetrants may be used:

A. **Metallic Penetrants** — The following types and sizes of metallic pipes, conduits or tubes may be used:

A1. **Steel Pipe** — Nom 2 in. (51 mm) diam (or smaller) Schedule 5 (or heavier) steel pipe.

A2. **Iron Pipe** — Nom 2 in. (51 mm) diam (or smaller) cast or ductile iron pipe.

A3. **Copper Pipe or Tubing** — Nom 2 in. (51 mm) diam (or smaller) Type L (or heavier) copper tube or Regular (or heavier) copper pipe.

A4. **Conduit** — Nom 2 in. (51 mm) diam (or smaller) rigid steel conduit or electrical metallic tubing (EMT).

B. **Nonmetallic Penetrants** — The following types and sizes of nonmetallic pipes, conduits or tubes may be used:

B1. **Polyvinyl Chloride (PVC) Pipe** — Nom 2 in. (51 mm) diam (or smaller) Schedule 40 solid or cellular core PVC pipe for use in closed (process or supply) or vented (drain, waste or vent) piping systems.

B2. **Chlorinated Polyvinyl Chloride (CPVC) Pipe** — Nom 2 in. (51 mm) diam (or smaller) SDR11 CPVC pipe for use in closed (process or supply) piping systems.

B3. **Rigid Nonmetallic Conduit (RNC)+** — Nom 2 in. (51 mm) diam (or smaller) Schedule 40 PVC conduit installed in accordance with the National Electrical Code (NFPA 70).

B4. **Cross Linked Polyethylene (PEX) Tubing** — Nom 1 in. (25 mm) diam (or smaller) SDR 9 PEX tubing for use in closed (process or supply) piping systems.

C. **Cables** — The following types of cables may be used:

C1. Max 100 pair No. 24 AWG (or smaller) copper conductor telecommunication cable with PVC insulation and jacketing.

C2. Max 3/C No. 3/0 AWG (or smaller) aluminum or copper conductor SER cable with PVC insulation and jacketing.

C3. Max 3/C with ground No. 8 AWG (or smaller) Type NM (Romex) nonmetallic sheathed cable with PVC insulation and jacketing.

C4. Max 7/C No. 12 AWG (or smaller) power/control cables with PVC insulation and jacketing.

C5. Max 4 pair No. 24 AWG (or smaller) copper conductor data cable with PVC insulation and jacketing.

C6. Max RG/U coaxial cable with copper conductor and fluorinated ethylene insulation and jacket.

C7. Max 4 pair No. 18 AWG (or smaller) copper conductor instrumentation cable with PVC insulation and jacketing.

C8. Fiber optic cable with PVC insulation and jacketing.

C9. **Through-Penetrating Products*** — Max 4/C with ground No. 2/0 AWG (or smaller) aluminum or copper conductor, aluminum or steel jacketed Metal-Clad+ or Armored-Clad+ cable.

3. **Fill, Void or Cavity Material* - Sealant** — Min 3/4 in. (19 mm) thickness of fill material applied within the annulus, flush with the top surface of the floor or chase wall sole plate. Min 5/8 in. (16 mm) thickness of fill material applied within the annulus, flush with bottom surface of gypsum board ceiling or chase wall top plate. Min 1/4 in. (6 mm) diam bead of fill material applied at point contact location on the top surface of floor or chase wall sole plate and at the penetrant/ceiling or penetrant/chase wall top plate interface.

RELIANCE WORLDWIDE CORPORATION DBA HOLDRITE HYDROFLAME — HydroFlame 100, HydroFlame 200

*** Indicates such products shall bear the UL or cUL Certification Mark for jurisdictions employing the UL or cUL Certification (such as Canada), respectively.**

+Bearing the UL Listing Mark

Last Updated on 2019-01-29

The appearance of a company's name or product in this database does not in itself assure that products so identified have been manufactured under UL's Follow-Up Service. Only those products bearing the UL Mark should be considered to be Certified and covered under UL's Follow-Up Service. Always look for the Mark on the product.

UL permits the reproduction of the material contained in the Online Certification Directory subject to the following conditions: 1. The Guide Information, Assemblies, Constructions, Designs, Systems, and/or Certifications (files) must be presented in their entirety and in a non-misleading manner, without any manipulation of the data (or drawings). 2. The statement "Reprinted from the Online Certifications Directory with permission from UL" must appear adjacent to the extracted material. In addition, the reprinted material must include a copyright notice in the following format: "© 2019 UL LLC"

XHEZ.W-L-2716 - THROUGH-PENETRATION FIRESTOP SYSTEMS

Design/System/Construction/Assembly Usage Disclaimer

- Authorities Having Jurisdiction should be consulted in all cases as to the particular requirements covering the installation and use of UL Certified products, equipment, system, devices, and materials.
- Authorities Having Jurisdiction should be consulted before construction.
- Fire resistance assemblies and products are developed by the design submitter and have been investigated by UL for compliance with applicable requirements. The published information cannot always address every construction nuance encountered in the field.
- When field issues arise, it is recommended the first contact for assistance be the technical service staff provided by the product manufacturer noted for the design. Users of fire resistance assemblies are advised to consult the general Guide Information for each product category and each group of assemblies. The Guide Information includes specifics concerning alternate materials and alternate methods of construction.
- Only products which bear UL's Mark are considered Certified.

XHEZ - Through-penetration Firestop Systems XHEZ7 - Through-penetration Firestop Systems Certified for Canada

See General Information for Through-penetration Firestop Systems

See General Information for Through-penetration Firestop Systems Certified for Canada

System No. W-L-2716

February 01, 2019

ANSI/UL1479 (ASTM E814)	CAN/ULC S115
F Ratings - 1 and 2 Hr (See Item 1)	F Ratings - 1 and 2 Hr (See Item 1)
T Rating - 0 Hr	FT Rating - 0 Hr
L Rating At Ambient - Less Than 1 CFM/sq ft	FH Ratings - 1 and 2 Hr (See Item 1)
L Rating At 400°F - Less Than 1 CFM/sq ft	FTH Ratings - 0 Hr
	L Rating At Ambient - Less Than 1 CFM/sq ft
	L Rating At 400°F - Less Than 1 CFM/sq ft

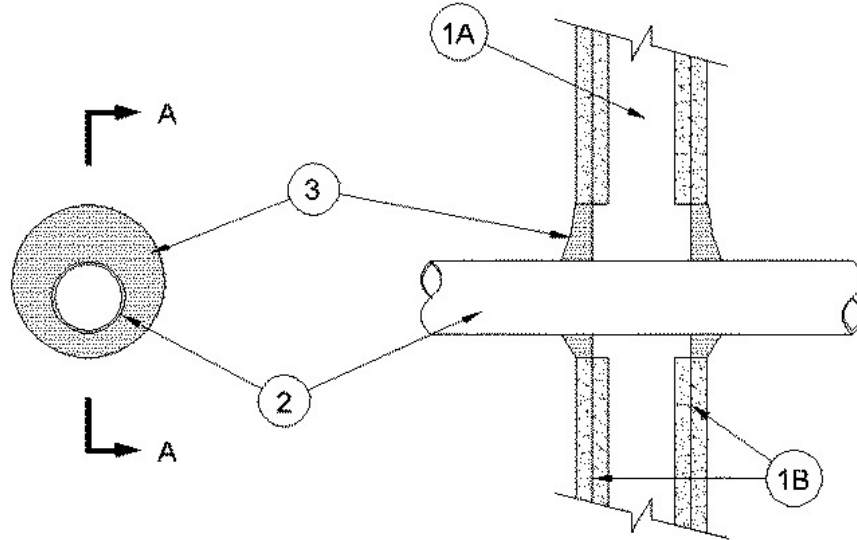

SECTION 'A-A'

1. **Wall Assembly** — The 1 or 2 hr fire rated gypsum board/stud wall assembly shall be constructed of the material and in the manner specified in the individual U300, U400 or V400 Series Wall and Partition Designs in the UL Fire Resistance Directory and shall include the following construction features.

A. **Studs** — Wall framing may consist of either wood studs or steel channel studs. Wood studs to consist of nom 2 by 4 in. (51 by 102 mm) lumber spaced 16 in. (406 mm) OC. Steel studs to be min 3-5/8 in. (92 mm) wide and spaced max 24 in. (610 mm) OC.

B. **Gypsum Board*** — Nom 5/8 in. (16 mm) thick, 4 ft (1.2 m) wide with square or tapered edges. The gypsum board thickness, type, number of layers, fasteners type and sheet orientation shall be as specified in the individual Wall and Partition Design. Max diam of opening is 4 in. (102 mm).

The hourly F Rating of the firestop system is equal to the hourly fire rating of the wall assembly in which it is installed.

2. **Nonmetallic Pipe** — One nonmetallic pipe or conduit to be installed either concentrically or eccentricity within the firestop system. The annular space between the through penetrant and the periphery of the opening shall be a min 5/8 in.(16 mm) to a max 1 in. (25 mm). Pipe or conduit to be rigidly supported on both sides of wall assembly. The following types of nonmetallic pipes or conduits may be used:

A. **Polyvinyl Chloride (PVC) Pipe** — Nom 2 in. (51 mm) diam (or smaller) Schedule 40 solid or cellular core PVC pipe for use in closed (process or supply) or vented (drain, waste, or vent) piping systems.

B. **Chlorinated Polyvinyl Chloride (CPVC) Pipe** — Nom 2 in. (51 mm) diam (or smaller) SDR 13.5 CPVC pipe for use in closed (process or supply) piping systems.

C. **Rigid Nonmetallic Conduit+** — Nom 2 in. (51 mm) diam (or smaller) Schedule 40 PVC conduit installed in accordance with the National Electrical Code, (NFPA No. 70).

D. **Acrylonitrile Butadiene Styrene (ABS) Pipe** — Nom 2 in. (51 mm) diam Schedule 40 cellular or solid core ABS pipe for use in closed (process or supply) or vented (drain, waste or vent) piping systems.

3. **Fill, Void, or Cavity Materials* - Sealant** — Min 5/8 in. (16 mm) thickness of fill material applied within the annulus, flush with both surfaces of wall. Additional fill material to be installed such that a min 1/4 in. (6 mm) thick crown is formed around the through penetrant at both surfaces of wall.

RELIANCE WORLDWIDE CORPORATION DBA HOLDRITE HYDROFLAME — HydroFlame 100

*** Indicates such products shall bear the UL or cUL Certification Mark for jurisdictions employing the UL or cUL Certification (such as Canada), respectively.**

+Bearing the UL Listing Mark

Last Updated on 2019-02-01

The appearance of a company's name or product in this database does not in itself assure that products so identified have been manufactured under UL's Follow-Up Service. Only those products bearing the UL Mark should be considered to be Certified and covered under UL's Follow-Up Service. Always look for the Mark on the product.

UL permits the reproduction of the material contained in the Online Certification Directory subject to the following conditions: 1. The Guide Information, Assemblies, Constructions, Designs, Systems, and/or Certifications (files) must be presented in their entirety and in a non-misleading manner, without any manipulation of the data (or drawings). 2. The statement "Reprinted from the Online Certifications Directory with permission from UL" must appear adjacent to the extracted material. In addition, the reprinted material must include a copyright notice in the following format: "© 2019 UL LLC"

XHEZ.W-L-2717 - THROUGH-PENETRATION FIRESTOP SYSTEMS

Design/System/Construction/Assembly Usage Disclaimer

- Authorities Having Jurisdiction should be consulted in all cases as to the particular requirements covering the installation and use of UL Certified products, equipment, system, devices, and materials.
- Authorities Having Jurisdiction should be consulted before construction.
- Fire resistance assemblies and products are developed by the design submitter and have been investigated by UL for compliance with applicable requirements. The published information cannot always address every construction nuance encountered in the field.
- When field issues arise, it is recommended the first contact for assistance be the technical service staff provided by the product manufacturer noted for the design. Users of fire resistance assemblies are advised to consult the general Guide Information for each product category and each group of assemblies. The Guide Information includes specifics concerning alternate materials and alternate methods of construction.
- Only products which bear UL's Mark are considered Certified.

XHEZ - Through-penetration Firestop Systems

See General Information for Through-penetration Firestop Systems

System No. W-L-2717

January 30, 2019

F Ratings — 1 and 2 Hr (See Item 1)

T Ratings — 1 and 2 Hr (See Item 1)

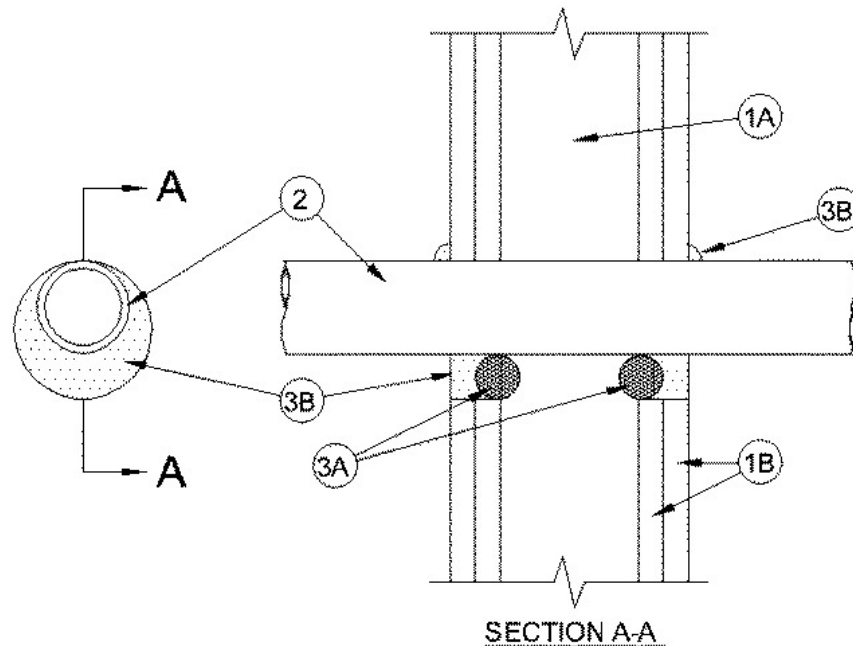

1. Wall Assembly — The 1 or 2 hour fire-rated gypsum board/stud wall assembly shall be constructed of the materials and in the manner specified in the individual U300 or U400 Series Wall and Partition Designs in the UL Fire Resistance Directory and shall include the following construction features:

A. Studs — Wall framing may consist of either wood studs or steel channel studs. Wood studs to consist of nom 2 by 4 inch (51 by 102 mm) lumber spaced 16 inch (406 mm) OC. Steel studs to be min 2-1/2 inch (64 mm) wide and spaced max 24 inch (610 mm) OC.

B. Gypsum Board* — 5/8 in. (16 mm) thick, 4 feet (1.2 m) wide with square or tapered edges. The gypsum board type, thickness, number of layers, fastener type and sheet orientation shall be as specified in the individual Wall and Partition Design. Maximum diameter of opening is 3-5/8 in. (92 mm).

The hourly F and T Ratings of the firestop system are equal to the hourly fire rating of the wall assembly.

2. Nonmetallic Pipe — One non-metallic pipe to be installed either concentrically or eccentrically within the firestop system. The annular space shall be min 0 (point contact) to max 1-1/4 in. (32 mm). Pipe to be rigidly supported on both sides of wall assembly. The following types and sizes of non-metallic pipes may be used:

A. Polyvinyl Chloride (PVC) Pipe — Nom 2 in. (51 mm) diam (or smaller) Schedule 40 solid core or cellular core PVC pipe for use in closed (process or supply) or vented (drain, waste or vent) piping systems.

B. Chlorinated Polyvinyl Chloride (CPVC) Pipe — Nom 2 in. (51 mm) diam (or smaller) SDR 13.5 CPVC pipe for use in closed (process or supply) piping systems.

C. Electrical Non-Metallic Tubing (ENT) — Nom 2 in. (51 mm) (or smaller) PVC tubing installed in accordance with Article 331 of the National Electrical Code (NFPA 70).

D. Cross Linked Polyethylene (PEX) Tubing — Nom 1 in. (25 mm) diam (or smaller) SDR 9 PEX tubing for use in closed (process or supply) piping systems.

3. Firestop System — The firestop system shall consist of the following:

A. Packing Material — (Optional) For 2 hr wall assemblies, foam backer rod firmly packed into opening as a permanent form. Packing material to be recessed from each surface of the wall to accommodate the required thickness of fill material.

B. Fill Void or Cavity Materials* - Caulk — Min 5/8 in. (16 mm) thickness of fill material applied within the annulus on both surfaces of the wall assembly. A min 1/2 in. (13 mm) diam bead of caulk shall be applied to the pipe/gypsum board interface at the point contact location on both sides of wall.

*** Indicates such products shall bear the UL or cUL Certification Mark for jurisdictions employing the UL or cUL Certification (such as Canada), respectively.**

Last Updated on 2019-01-30

The appearance of a company's name or product in this database does not in itself assure that products so identified have been manufactured under UL's Follow-Up Service. Only those products bearing the UL Mark should be considered to be Certified and covered under UL's Follow-Up Service. Always look for the Mark on the product.

UL permits the reproduction of the material contained in the Online Certification Directory subject to the following conditions: 1. The Guide Information, Assemblies, Constructions, Designs, Systems, and/or Certifications (files) must be presented in their entirety and in a non-misleading manner, without any manipulation of the data (or drawings). 2. The statement "Reprinted from the Online Certifications Directory with permission from UL" must appear adjacent to the extracted material. In addition, the reprinted material must include a copyright notice in the following format: "© 2019 UL LLC"

XHEZ.W-L-3455 - THROUGH-PENETRATION FIRESTOP SYSTEMS

Design/System/Construction/Assembly Usage Disclaimer

- Authorities Having Jurisdiction should be consulted in all cases as to the particular requirements covering the installation and use of UL Certified products, equipment, system, devices, and materials.
- Authorities Having Jurisdiction should be consulted before construction.
- Fire resistance assemblies and products are developed by the design submitter and have been investigated by UL for compliance with applicable requirements. The published information cannot always address every construction nuance encountered in the field.
- When field issues arise, it is recommended the first contact for assistance be the technical service staff provided by the product manufacturer noted for the design. Users of fire resistance assemblies are advised to consult the general Guide Information for each product category and each group of assemblies. The Guide Information includes specifics concerning alternate materials and alternate methods of construction.
- Only products which bear UL's Mark are considered Certified.

XHEZ - Through-penetration Firestop Systems XHEZ7 - Through-penetration Firestop Systems Certified for Canada

See General Information for Through-penetration Firestop Systems

See General Information for Through-penetration Firestop Systems Certified for Canada

System No. W-L-3455

February 01, 2019

ANSI/UL1479 (ASTM E814)	CAN/ULC S115
F Ratings — 1 and 2 Hr (See Item 1)	F Ratings — 1 and 2 Hr (See Item 1)
T Ratings — 0 and 1/2 Hr (See Items 1 and 2)	FT Ratings — 0 and 1/2 Hr (See Items 1 and 2)
	FH Ratings — 1 and 2 Hr (See Item 1)Hr
	FTH Ratings — 0 and 1/2 Hr (See Items 1 and 2)

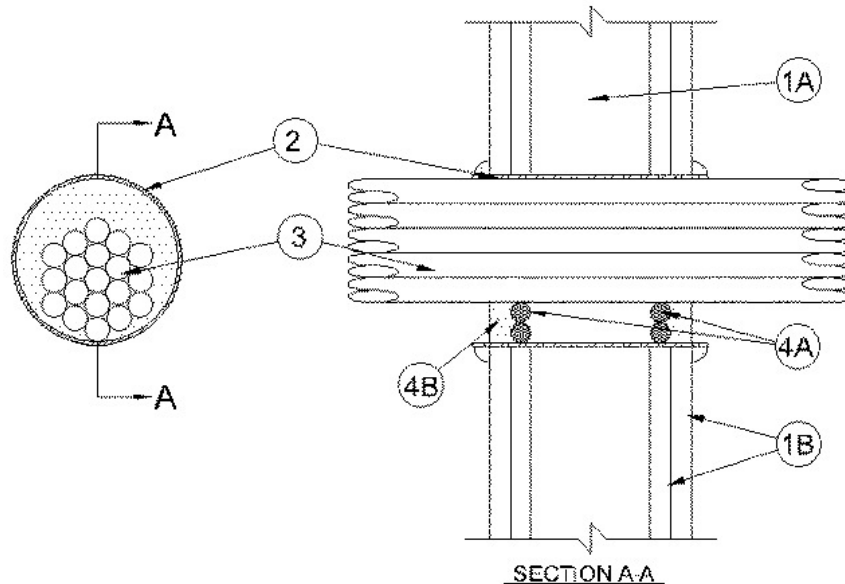

1. Wall Assembly — The 1 or 2 hr fire-rated gypsum board/stud wall assembly shall be constructed of the materials and in the manner specified in the individual U300, U400, V400 or W400 Series Wall and Partition Designs in the UL Fire Resistance Directory and shall include the following construction features:

A. Studs — Wall framing may consist of either wood studs or steel channel studs. Wood studs to consist of nom 2 by 4 in. (51 by 102 mm) lumber spaced 16 in. (406 mm) OC. Steel studs to be min 3-1/2 in. (89 mm) wide and spaced max 24 in. (610 mm) OC.

B. Gypsum Board* — One or two layers of nom 5/8 in. (16 mm) thick gypsum board as specified in the individual Wall and Partition Design. Max diam of opening is 4 in. (102 mm).
The hourly F and FH Ratings of the firestop system are equal to the hourly fire rating of the wall assembly. The T, FT and FTH Rating is 0 and 1/2 for 1 and 2 Hr assemblies, respectively.

2. Steel Sleeve — (Optional) — Max 4 in. (102 mm) diam sleeve fabricated from min 0.018 in. (0.46 mm) thick (28 gauge) galv sheet steel and floor or wall assembly, inserted opening and allowed to uncoil against the circular cutouts. Sleeve to be installed flush with or extending max 1 in. (25 mm) beyond each surface of the wall assembly.

2A. Steel Sleeve — (Optional) - As an alternate to Item 2, max 4 in. (102 mm) Schedule 5 (or heavier) steel pipe, rigid steel conduit or EMT, friction-fit into wall assembly, flush with or extending a max 4 in. (102 mm) beyond each surface of the floor or wall assembly.

When steel sleeve is used, T, FT and FTH Ratings are 0 hr.

3. Cables — Aggregate cross-sectional area of cables to be min 25 percent to max 64 percent of the aggregate cross-sectional area of the opening. Cables to be tightly bundled and rigidly supported on both sides of wall assembly. The annular space between the cables and the periphery of opening shall be min 0 in. (point contact) to max 2 in. (51 mm). Any combination of following types and sizes of copper conductor cables may be used:

A. Max 2/C with ground, No. 12 AWG MC (BX) cable with polyvinyl chloride (PVC) insulation on conductors inside a steel armored jacket.

- B. Max 3/C with ground, No. 12 AWG (or smaller) nonmetallic sheathed (Romex) cable with copper conductors, PVC insulation and jacket.
- C. Max 8/C No. 12 AWG (or smaller) Type SOW-A P-123-70-MSHA.
- D. Max 25 pair, No. 24 AWG (or smaller) copper conductor telephone cable with XLPE/PVC insulation, with or without PVC jacket.
- E. Max RG6 (or smaller) television coaxial cable CATVX.
- F. Max 4 pair, No. 24 AWG (or smaller) copper conductor data cable with Hylar insulation and jacketing.
- G. Max 1/C, No. 18 AWG (or smaller) Type MTW or THHN or THWN or gas & oil res II 600V (UL) or AWM VW-1 power cable.
- H. Max 1/C, No. 14 AWG (or smaller) Type MTW or THHN or THWN or gas & oil res II 600V (UL) or AWM VW-1 power cable.
- I. Max 1/C, No. 10 AWG (or smaller) Type THHN or THWN gasoline & oil resistant II 600V VW-1 E116364 (UL) power cable.
- J. Optical Fiber Cable max 62.5/125 Type UFNH.
- K. Max 3/C, No. 4/0 with ground, AWG aluminum Triple E Alloy AA8176 Type SE cable Style U Type XHH-W-2 CDRS E32071 (UL) service entrance cable.
- L. Max 3/C, No. 18 AWG with ground and shield E120910.

4. **Firestop System** — The firestop system shall consist of the following:

A. **Fill, Void or Cavity Material* - Caulk** — Min 1/2 in. (13 mm) thickness of fill material applied within the annulus, flush with both surfaces of wall. When steel sleeve is not used or when steel sleeve is flush with the wall surfaces, a min 1/4 in. (6 mm) diam bead of caulk shall be applied at interface of cables and periphery of opening at point contact location on both surfaces of wall. When steel sleeve is used, a bead of caulk is applied to the steel sleeve/gypsum board interface on both sides of wall. When sheet metal sleeve (Item 2) is used, fill material to be installed flush with both surfaces of wall within the sleeve. When rigid steel sleeve (Item 2A) is used, fill material may be installed flush with both ends of sleeve in walls.

RELIANCE WORLDWIDE CORPORATION DBA HOLDRITE HYDROFLAME — HydroFlame 100, HydroFlame 200

*** Indicates such products shall bear the UL or cUL Certification Mark for jurisdictions employing the UL or cUL Certification (such as Canada), respectively.**

Last Updated on 2019-02-01

The appearance of a company's name or product in this database does not in itself assure that products so identified have been manufactured under UL's Follow-Up Service. Only those products bearing the UL Mark should be considered to be Certified and covered under UL's Follow-Up Service. Always look for the Mark on the product.

UL permits the reproduction of the material contained in the Online Certification Directory subject to the following conditions: 1. The Guide Information, Assemblies, Constructions, Designs, Systems, and/or Certifications (files) must be presented in their entirety and in a non-misleading manner, without any manipulation of the data (or drawings). 2. The statement "Reprinted from the Online Certifications Directory with permission from UL" must appear adjacent to the extracted material. In addition, the reprinted material must include a copyright notice in the following format: "© 2019 UL LLC"

XHEZ.W-L-3457 - THROUGH-PENETRATION FIRESTOP SYSTEMS

Design/System/Construction/Assembly Usage Disclaimer

- Authorities Having Jurisdiction should be consulted in all cases as to the particular requirements covering the installation and use of UL Certified products, equipment, system, devices, and materials.
- Authorities Having Jurisdiction should be consulted before construction.
- Fire resistance assemblies and products are developed by the design submitter and have been investigated by UL for compliance with applicable requirements. The published information cannot always address every construction nuance encountered in the field.
- When field issues arise, it is recommended the first contact for assistance be the technical service staff provided by the product manufacturer noted for the design. Users of fire resistance assemblies are advised to consult the general Guide Information for each product category and each group of assemblies. The Guide Information includes specifics concerning alternate materials and alternate methods of construction.
- Only products which bear UL's Mark are considered Certified.

XHEZ - Through-penetration Firestop Systems XHEZ7 - Through-penetration Firestop Systems Certified for Canada

See General Information for Through-penetration Firestop Systems

See General Information for Through-penetration Firestop Systems Certified for Canada

System No. W-L-3457

February 11, 2019

ANSI/UL1479 (ASTM E814)	CAN/ULC S115
F Ratings — 1 and 2 Hr (See Item 1)	F Ratings — 1 and 2 Hr (See Item 1)
T Rating — 0 Hr	FT Rating — 0 Hr
	FH Ratings — 1 and 2 Hr (See Item 1)
	FTH Rating — 0 Hr

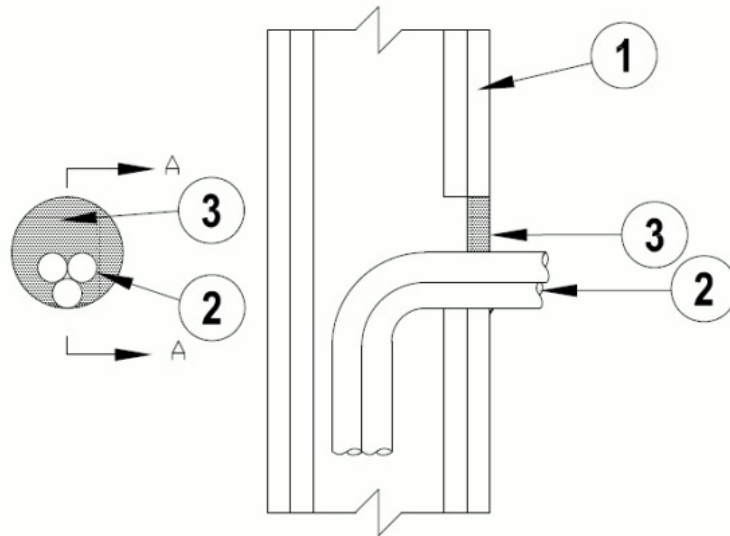

SECTION A-A

1. Wall Assembly — The 1 or 2 hr fire-rated gypsum board/stud wall assembly shall be constructed of the materials and in the manner specified in the individual U300, U400, V400 or W400 Series Wall and Partition Designs in the UL Fire Resistance Directory and shall include the following construction features:

A. Studs — Wall framing may consist of either wood studs or steel channel studs. Wood studs to consist of nom 2 by 4 in. (51 by 102 mm) lumber spaced 16 in. (406 mm) OC. Steel studs to be min 3-1/2 in. (89 mm) wide and spaced max 24 in. (610 mm) OC.

B. Gypsum Board* — One or two layers of nom 5/8 in. (16 mm) thick gypsum board as specified in the individual Wall and Partition Design. Max diam of opening is 4 in. (102 mm).

The hourly F and FH Ratings of the firestop system are equal to the hourly fire rating of the wall assembly.

2. Cables — Max of three tightly bundled 3/C (with ground) No. 8 AWG bare copper ground metal clad cables with a PVC jacket. Annular space between cable bundle and periphery of opening shall be a min 0 in. (point contact) to a max 2 in. (51 mm). Cables to be rigidly supported on penetrated side of wall assembly.

3. Fill, Void or Cavity Material*— Sealant — Min 5/8 in. (16 mm) thickness of fill material applied within annulus, flush with surface of wall. Min 1/4 in. (6 mm) diam bead of sealant applied at point contact location.

RELIANCE WORLDWIDE CORPORATION DBA HOLDRITE HYDROFLAME — HydroFlame 100, HydroFlame 200

*** Indicates such products shall bear the UL or cUL Certification Mark for jurisdictions employing the UL or cUL Certification (such as Canada), respectively.**

Last Updated on 2019-02-11

The appearance of a company's name or product in this database does not in itself assure that products so identified have been manufactured under UL's Follow-Up Service. Only those products bearing the UL Mark should be considered to be Certified and covered under UL's Follow-Up Service. Always look for the Mark on the product.

UL permits the reproduction of the material contained in the Online Certification Directory subject to the following conditions: 1. The Guide Information, Assemblies, Constructions, Designs, Systems, and/or Certifications (files) must be presented in their entirety and in a non-misleading manner, without any manipulation of the data (or drawings). 2. The statement "Reprinted from the Online Certifications Directory with permission from UL" must appear adjacent to the extracted material. In addition, the reprinted material must include a copyright notice in the following format: "© 2019 UL LLC"

XHEZ.W-L-3458 - THROUGH-PENETRATION FIRESTOP SYSTEMS

Design/System/Construction/Assembly Usage Disclaimer

- Authorities Having Jurisdiction should be consulted in all cases as to the particular requirements covering the installation and use of UL Certified products, equipment, system, devices, and materials.
- Authorities Having Jurisdiction should be consulted before construction.
- Fire resistance assemblies and products are developed by the design submitter and have been investigated by UL for compliance with applicable requirements. The published information cannot always address every construction nuance encountered in the field.
- When field issues arise, it is recommended the first contact for assistance be the technical service staff provided by the product manufacturer noted for the design. Users of fire resistance assemblies are advised to consult the general Guide Information for each product category and each group of assemblies. The Guide Information includes specifics concerning alternate materials and alternate methods of construction.
- Only products which bear UL's Mark are considered Certified.

XHEZ - Through-penetration Firestop Systems XHEZ7 - Through-penetration Firestop Systems Certified for Canada

See General Information for Through-penetration Firestop Systems

See General Information for Through-penetration Firestop Systems Certified for Canada

System No. W-L-3458

February 11, 2019

ANSI/UL1479 (ASTM E814)	CAN/ULC S115
F Ratings — 1 & 2 Hr (See Item 1)	F Ratings — 1 & 2 Hr (See Item 1)
T Ratings — 1 & 2 Hr (See Item 1)	FT Ratings — 1 & 2 Hr (See Item 1)
	FH Ratings — 1 & 2 Hr (See Item 1)
	FTH Ratings — 1 & 2 Hr (See Item 1)

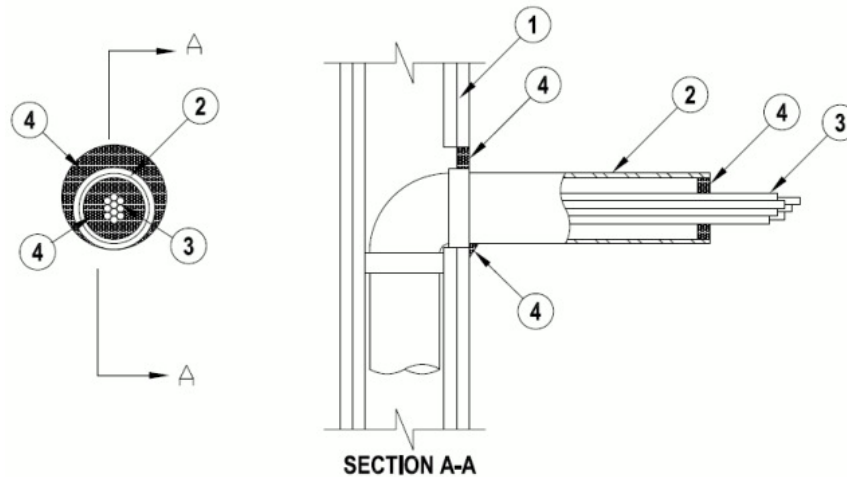

1. Wall Assembly — The 1 or 2 hr fire-rated gypsum board/stud wall assembly shall be constructed of the materials and in the manner specified in the individual U300, U400, V400 or W400 Series Wall and Partition Designs in the UL Fire Resistance Directory and shall include the following construction features:

A. Studs — Wall framing may consist of either wood studs or steel channel studs. Wood studs to consist of nom 2 by 4 in. (51 by 102 mm) lumber spaced 16 in. (406 mm) OC. Steel studs to be min 3-5/8 in. (91 mm) wide and spaced max 24 in. (610 mm) OC.

B. Gypsum Board* — One or two layers of nom 5/8 in. (16 mm) thick gypsum board as specified in the individual Wall and Partition Design. Opening may be circular or elliptical in shape. Max diam of opening is 6-1/2 in. (165 mm) with max area of 17.87 in².

The hourly F, T, FH and FTH Ratings of the firestop system are equal to the hourly fire rating of the wall assembly.

2. Sleeve — Nom 3 in. (76 mm) diam (or smaller) steel EMT, steel conduit or Schedule 5 (or heavier) steel pipe. The steel sleeve may be installed at an angle not greater than 45 degrees from perpendicular. The annular space between sleeve and periphery of opening shall be min. 0 in. (point contact) to max 1 in. (25 mm). Maximum projection from wall is 12 in. (305 mm). Sleeve to be rigidly supported on penetrated side of wall assembly.

3. Cables — Aggregate cross-sectional area of cables to be min 25 percent to max 64 percent of the aggregate cross-sectional area of the opening. Cables to be tightly bundled and rigidly supported on the penetrated side of wall assembly. The annular space between the cables and the sleeve shall be min 0 in. (point contact) to max 2 in. (51 mm). Any combination of following types and sizes of copper conductor cables may be used:

A. Max 2/C with ground, No. 12 AWG MC (BX) cable with polyvinyl chloride (PVC) insulation on conductors inside a steel armored jacket.

B. Max 3/C with ground, No. 12 AWG (or smaller) nonmetallic sheathed (Romex) cable with copper conductors, PVC insulation and jacket.

C. Max 8/C No. 12 AWG (or smaller) Type SOW-A P-123-70-MSHA.

D. Max 25 pair, No. 24 AWG (or smaller) copper conductor telephone cable with XLPE/PVC insulation, with or without PVC jacket.

E. Max RG6 (or smaller) television coaxial cable CATVX.

F. Max 4 pair, No. 24 AWG (or smaller) copper conductor data cable with Hylar insulation and jacketing.

G. Max 1/C, No. 18 AWG (or smaller) Type MTW or THHN or THWN or gas & oil res II 600V (UL) or AWM VW-1 power cable.

H. Max 1/C, No. 14 AWG (or smaller) Type MTW or THHN or THWN or gas & oil res II 600V (UL) or AWM VW-1 power cable.

I. Max 1/C, No. 10 AWG (or smaller) Type THHN or THWN gasoline & oil resistant II 600V VW-1 E116364 (UL) power cable.

J. Optical Fiber Cable max 62.5/125 Type UFNH.

K. Max 3/C, No. 4/0 with ground, AWG aluminum Triple E Alloy AA8176 Type SE cable Style U Type XHH-W-2 CDRS E32071 (UL) service entrance cable.

L. Max 3/C, No. 18 AWG with ground and shield E120910.

4. **Fill, Void or Cavity Material*— Sealant** — Min 5/8 in. (16 mm) thickness of fill material applied within the annulus, flush with surface of wall. Min. 1/2 in. thickness of fill material installed within the sleeve, flush with the end of the sleeve. Min 1/4 in. (6 mm) diam bead of sealant applied at point contact location.

RELIANCE WORLDWIDE CORPORATION DBA HOLDRITE HYDROFLAME — HydroFlame 100, HydroFlame 200

5. **Packing Material** — (Optional, Not Shown) — Mineral wool forming material or foam backer rod may be used as a backer for the sealant. When used, it shall be firmly packed into annular space between cables and sleeve as a permanent form and recessed from end of sleeve to accommodate the required thickness of fill material.

*** Indicates such products shall bear the UL or cUL Certification Mark for jurisdictions employing the UL or cUL Certification (such as Canada), respectively.**

Last Updated on 2019-02-11

The appearance of a company's name or product in this database does not in itself assure that products so identified have been manufactured under UL's Follow-Up Service. Only those products bearing the UL Mark should be considered to be Certified and covered under UL's Follow-Up Service. Always look for the Mark on the product.

UL permits the reproduction of the material contained in the Online Certification Directory subject to the following conditions: 1. The Guide Information, Assemblies, Constructions, Designs, Systems, and/or Certifications (files) must be presented in their entirety and in a non-misleading manner, without any manipulation of the data (or drawings). 2. The statement "Reprinted from the Online Certifications Directory with permission from UL" must appear adjacent to the extracted material. In addition, the reprinted material must include a copyright notice in the following format: "© 2019 UL LLC"

XHEZ.W-L-7291 - THROUGH-PENETRATION FIRESTOP SYSTEMS

Design/System/Construction/Assembly Usage Disclaimer

- Authorities Having Jurisdiction should be consulted in all cases as to the particular requirements covering the installation and use of UL Certified products, equipment, system, devices, and materials.
- Authorities Having Jurisdiction should be consulted before construction.
- Fire resistance assemblies and products are developed by the design submitter and have been investigated by UL for compliance with applicable requirements. The published information cannot always address every construction nuance encountered in the field.
- When field issues arise, it is recommended the first contact for assistance be the technical service staff provided by the product manufacturer noted for the design. Users of fire resistance assemblies are advised to consult the general Guide Information for each product category and each group of assemblies. The Guide Information includes specifics concerning alternate materials and alternate methods of construction.
- Only products which bear UL's Mark are considered Certified.

XHEZ - Through-penetration Firestop Systems XHEZ7 - Through-penetration Firestop Systems Certified for Canada

See General Information for Through-penetration Firestop Systems

See General Information for Through-penetration Firestop Systems Certified for Canada

System No. W-L-7291

February 14, 2019

ANSI/UL1479 (ASTM E814)	CAN/ULC S115
F Ratings — 1 and 2 Hr (See Item 1)	F Ratings — 1 and 2 Hr (See Item 1)
T Rating — 0 Hr	FT Rating — 0 Hr
	FH Ratings — 1 and 2 Hr (See Item 1)
	FTH Rating — 0 Hr

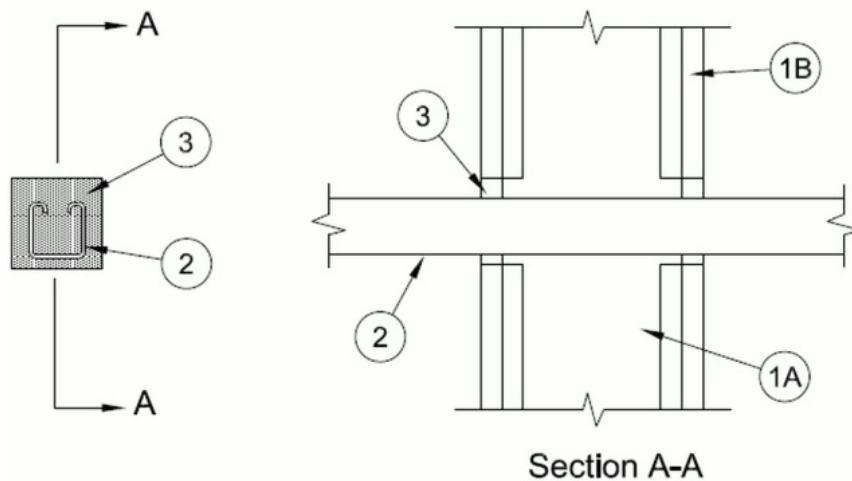

1. Wall Assembly — The 1 or 2 hr fire rated gypsum board/stud wall assembly shall be constructed of the materials and in the manner specified in the individual U300, U400, V400 or W400 Series Wall and Partition Designs in the UL Fire Resistance Directory and shall include the following construction features:

A. Studs — Wall framing may consist of either wood studs or steel channel studs. Wood studs to consist of nom 2 by 4 in. (51 by 102 mm) lumber spaced max 16 in. (406 mm) OC. Steel studs to be min 2-1/2 in. (64 mm) wide and spaced max 24 in. (610 mm) OC.

B. Gypsum Board* — One or two layers of gypsum board, as specified in the individual Wall and Partition Design. Max diam of opening is 3-3/8 in. (86 mm). Max area of rectangular opening is 16.5 sq in. (106 cm²) with max dimension of 5 in. (127 mm).

The hourly F and FH Ratings of the firestop system are equal to the hourly fire rating of the wall assembly in which it is installed.

2. Through Penetrants — One metallic strut, cable or rod service support to be installed within the firestop system. An annular space of min 1/8 in. (3 mm) to max 7/8 in. (22 mm) is required within the firestop system. Strut, cable or rod service support to be rigidly supported on both sides of wall assembly. The strut, cable or rod service support may be installed at an angle not greater than 45 degrees from the perpendicular. The following types and sizes of metallic strut, cable or rod service support may be used:

A. Steel Strut — Max 1-5/8 by 1-5/8 in. (41 by 41 mm) channel strut formed from min 0.105 in. (2.7 mm) thick galv or painted steel.

B. Steel Strut — Max 3-1/4 by 1-5/8 in. (83 by 41 mm) H strut formed from min 0.105 in. (2.7 mm) thick galv or painted steel.

C. Cable — Max 3/8 in. (9.5 mm) diam unjacketed galv steel cable.

D. Threaded Rod — Max 5/8 in. (16 mm) diam galv steel threaded rod.

3. **Fill, Void or Cavity Material* - Caulk or Sealant** — Min 5/8 in. (16 mm) thickness of fill material applied within the annulus and within the channel struts, flush with both surfaces of wall.
RELIANCE WORLDWIDE CORPORATION DBA HOLDRITE HYDROFLAME — HydroFlame 100, HydroFlame 200

*** Indicates such products shall bear the UL or cUL Certification Mark for jurisdictions employing the UL or cUL Certification (such as Canada), respectively.**

Last Updated on 2019-02-14

The appearance of a company's name or product in this database does not in itself assure that products so identified have been manufactured under UL's Follow-Up Service. Only those products bearing the UL Mark should be considered to be Certified and covered under UL's Follow-Up Service. Always look for the Mark on the product.

UL permits the reproduction of the material contained in the Online Certification Directory subject to the following conditions: 1. The Guide Information, Assemblies, Constructions, Designs, Systems, and/or Certifications (files) must be presented in their entirety and in a non-misleading manner, without any manipulation of the data (or drawings). 2. The statement "Reprinted from the Online Certifications Directory with permission from UL" must appear adjacent to the extracted material. In addition, the reprinted material must include a copyright notice in the following format: "© 2019 UL LLC"

XHEZ.W-L-8119 - THROUGH-PENETRATION FIRESTOP SYSTEMS

Design/System/Construction/Assembly Usage Disclaimer

- Authorities Having Jurisdiction should be consulted in all cases as to the particular requirements covering the installation and use of UL Certified products, equipment, system, devices, and materials.
- Authorities Having Jurisdiction should be consulted before construction.
- Fire resistance assemblies and products are developed by the design submitter and have been investigated by UL for compliance with applicable requirements. The published information cannot always address every construction nuance encountered in the field.
- When field issues arise, it is recommended the first contact for assistance be the technical service staff provided by the product manufacturer noted for the design. Users of fire resistance assemblies are advised to consult the general Guide Information for each product category and each group of assemblies. The Guide Information includes specifics concerning alternate materials and alternate methods of construction.
- Only products which bear UL's Mark are considered Certified.

XHEZ - Through-penetration Firestop Systems XHEZ7 - Through-penetration Firestop Systems Certified for Canada

See General Information for Through-penetration Firestop Systems

See General Information for Through-penetration Firestop Systems Certified for Canada

System No. W-L-8119

February 15, 2019

ANSI/UL1479 (ASTM E814)	CAN/ULC 515
F Rating — 1 and 2 Hr (See Item 1)	F Rating — 1 and 2 Hr (See Item 1)
T Rating — 0, 1/2 and 1 Hr (See Items 2 and 3)	FT Rating — 0, 1/2 and 1 Hr (See Items 2 and 3)
	FH Rating — 1 and 2 Hr See Item 1)
	FTH Rating — 0, 1/2 and 1 Hr (See Items 2 and 3)

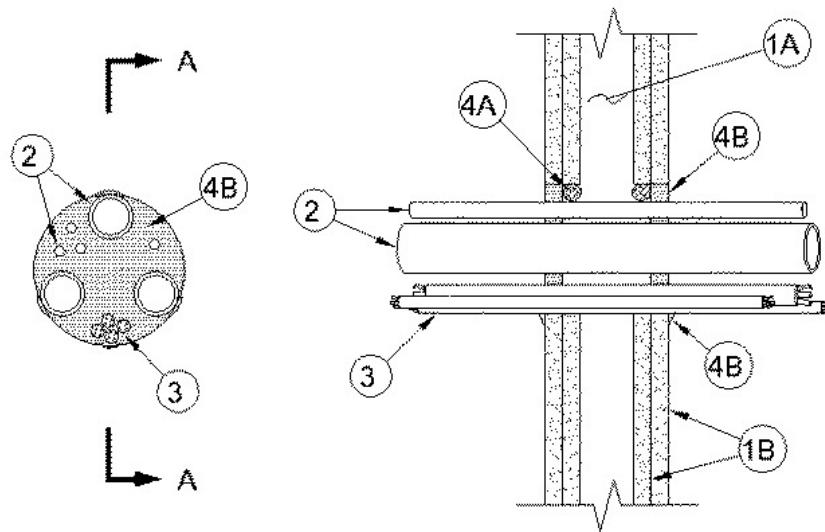

SECTION 'A-A'

1. **Wall Assembly** — The 1 or 2 hr fire rated gypsum board/stud wall assembly shall be constructed of the materials and in the manner specified in the individual U300 or U400 Series Wall or Partition Design in the UL Fire Resistance Directory and shall include the following construction features:

A. **Studs** — Wall framing may consist of either wood studs or steel channel studs. Wood studs to consist of nom 2 by 4 in. (51 by 102 mm) lumber spaced 16 in. (406 mm) OC. Steel studs to be min 3-5/8 in. (92 mm) wide and spaced max 24 in. (610 mm)

B. **Gypsum Board*** — Thickness, type, number of layers and fasteners as specified in the individual Wall and Partition Design. Max diam of opening is 10 in. (254 mm)

The hourly F Rating of the firestop system is equal to the hourly fire rating of the wall assembly in which it is installed.

2. **Through Penetrants** — A max of four 1 in. (25 mm) diam. and three 4 in. (102 mm) diam. (or smaller) metallic pipes, conduits or tubing to be installed within the firestop system. The annular space between the pipes, conduits or tubing and the periphery of the opening shall be min 0 in. (0 mm) (point contact) to max 1-1/2 in. (38 mm). Separation between pipes, conduits or tubing shall be min 1/2 in. (13 mm) to max 1-5/8 in. (41 mm). Pipes, conduits or tubing to be rigidly supported on both sides of the wall assembly. The following types and sizes of pipes, conduits and tubes may be used:

A. **Steel Pipe** — Nom 4 in. (102 mm) diam (or smaller) Schedule 5 (or heavier) steel pipe.

B. **Iron Pipe** — Nom 4 in. (102 mm) diam (or smaller) cast or ductile iron pipe.

C. **Conduit** — Nom 4 in. (102 mm) diam (or smaller) rigid steel conduit or nom 4 in. (102 mm) diam (or smaller) steel electrical metallic tubing (EMT).

D. **Copper Pipe** — Nom 4 in. (102 mm) diam (or smaller) Regular (or heavier) copper pipe.

E. **Copper Tube** — Nom 4 in. (102 mm) diam (or smaller) Type L (or heavier) copper tube.

F. **Copper Pipe** — Nom 1 in. (25 mm) diam Type K copper pipe.

When any metallic penetrant is used the T Rating is 0 hr.

3. **Cables** — Nom 3 in. (76 mm) diam. (or smaller) tight bundle of cables. Cable bundle spaced min 1 in. (25 mm) from other penetrants. Annular space between cable bundle and periphery of opening to be min 0 in. (0 mm) (point contact) to max 1-1/2 in. (38 mm). Cable bundle to be rigidly supported on both sides of wall assembly. Any combination of the following types and sizes of cables may be used:

A. Max 400 pairs, 24 AWG telephone communication cable with PVC insulation and jacket.

B. 4/C No. 14 AWG (or smaller) copper conductor PVC jacketed aluminum clad or steel clad TEK cable with XLPE insulation.

C. Max 7/C No. 12 AWG copper conductor power and control cables; XLPE or PVC insulation with XLPE or PVC jacket.

D. Max RG59/U (or smaller) coaxial cable with fluorinated ethylene insulation and jacketing.

E. Type RG 59/U coaxial cable with polyethylene (PE) insulation and PVC jacket.

When cable bundle is used without any metallic penetrant the T rating is 1/2 hr and 1 hr for 1 hr and 2hr fire rated wall assemblies, respectively.

4. **Firestop System** — The firestop system shall consist of the following items:

A. **Packing Material** — Foam plastic backer material or backer rod or mineral wool batt insulation firmly packed into opening as a permanent form. Packing material to be recessed from both surfaces of wall as required to accommodate the required thickness of fill material. When annular space between penetrants and/or between penetrants and edge of opening is 3/4 in. (19 mm) or less packing material is optional.

B. **Fill, Void or Cavity Material* — Sealant** — Min 5/8 in. (16 mm) thickness of fill material applied within annulus, flush with both surfaces of wall assembly. At point contact locations, min 1/2 in (13 mm) diam bead of fill material applied at through penetrant/gypsum board interface on both surfaces of wall.

RELIANCE WORLDWIDE CORPORATION DBA HOLDRITE HYDROFLAME — HydroFlame 100

*** Indicates such products shall bear the UL or cUL Certification Mark for jurisdictions employing the UL or cUL Certification (such as Canada), respectively.**

Last Updated on 2019-02-15

The appearance of a company's name or product in this database does not in itself assure that products so identified have been manufactured under UL's Follow-Up Service. Only those products bearing the UL Mark should be considered to be Certified and covered under UL's Follow-Up Service. Always look for the Mark on the product.

UL permits the reproduction of the material contained in the Online Certification Directory subject to the following conditions: 1. The Guide Information, Assemblies, Constructions, Designs, Systems, and/or Certifications (files) must be presented in their entirety and in a non-misleading manner, without any manipulation of the data (or drawings). 2. The statement "Reprinted from the Online Certifications Directory with permission from UL" must appear adjacent to the extracted material. In addition, the reprinted material must include a copyright notice in the following format: "© 2019 UL LLC"

PRODUCT SPECIFICATION SHEET

HoldRite® HydroFlame™ 50 Smoke & Acoustical Sealant



HydroFlame 50 is a smoke and acoustic sealant used to seal around penetrations in NON-RATED horizontal or vertical construction assemblies. Works in conjunction with and compliments the HoldRite Silencer System. When properly installed, HydroFlame 50 will prevent the passage of cold smoke through a penetration opening of the non-rated assembly while also providing an excellent sound barrier by preventing the transfer of airborne sound and other vibrations from passing through.

Product information:

- **Material Properties:** HydroFlame 50 does not contain any of the following: Asbestos fillers, hazardous ingredients or solvents. Application: Approximate 20-ounce caulking gun. Density: 10.5 +/- 0.5 lbs./gal (1.25 kg/L). Product color WHITE. Elastomeric and flexible. PH Value 6.5 - 7. Freeze/thaw -- exceptional. L Rating <1 cfm/sq. ft. (penetrations). VOC <10g/L. Class II and III movement capability +/-33% in accordance to ASTM E 1399. STC rating of 69. ASTM G21 mold resistant.
- **Application:** HydroFlame 50 is an acrylic-latex smoke and acoustic sealant designed for use with both vertical and horizontal through-penetrations in non-rated assemblies. HF50 can be used on a variety of metallic pipes and/or insulated pipes including cast iron, steel, steel conduits and copper as well as non-metallic combustible pipes. Compatible pipe materials include PVC, CPVC, ABS, PVDF PEX, and PP pipes. It will also seal around various cables/bundles and sheet metal ductwork.
- **Availability:** HydroFlame 50 is available in 20.2 oz. sausages only.
- **Limitations:** HydroFlame 50 should not be used in areas where it will be submerged in water or in continuously damp environments and is NOT designed for use in fire rated assemblies. It should not be installed in areas where surface temperatures are greater than 120°F (49°C).
- **Storage & Handling:** HydroFlame 50 Should be stored between 35°F (2°C) and 120°F (49°C) to obtain a 2-year shelf life, subject to inspection. NOTE: Do not dilute, no mixing is required. Keep from freezing. Keep products stored under protective cover in original containers.

Product Submittal	
Job Name:	
Date:	
Part Number:	Qty:
Architect / Owner:	
Contractor:	
Notes:	



THIS INFORMATION IS PROPRIETARY TO HOLDRITE AND IS SUBJECT TO CHANGE WITHOUT NOTICE. IT MAY NOT BE REPRODUCED IN PART OR WHOLE WITHOUT WRITTEN AUTHORIZATION.



- **Testing Data:** HydroFlame 50 has been tested to meet the following ASTM standards: ASTM E84, ASTM E1399, and a modified UL 1479 and/or ASTM E814. Note: air leakage was tested at ambient room temperature. ASTM G21 Mold resistant. ASTM E84 (UL 723 Tunnel Test). Flame Spread = 5. Smoke Index = 0. STC rating at 69, (based on ASTM E90 testing on a U411 wall design). This product is Clean Air Gold certified.
- **Compatibility:** “FBC™ System Compatible indicates that these products has been tested, and is monitored on an ongoing basis, to assure its chemical compatibility with FlowGuard Gold®, BlazeMaster® and Corzan® piping systems and products made with TempRite® Technology.” “The FBC Compatible Logo, FBC™, FlowGuard Gold®, BlazeMaster®, Corzan®, and TempRite® are trademarks of Lubrizol Advanced Materials Inc. or its affiliates.”
- **Features:** Easily dispensed using a 20-ounce caulking gun. Provides a flexible paintable sealant once cured. Meets Leed criteria. Low VOC content. Easily cleans up with water. FBC™ System Compatible. This product is Clean Air Gold certified.
- **Installation Data:** Step 1: Create opening in substrate and install penetrating item(s) in accordance with local standards and building codes. Step 2: Thoroughly clean all wall or floor substrate and penetrant surfaces. Ensure surfaces are free from any dust, debris, wax, oil, moisture and other contaminates. Step 3: Install backing material if needed. Step 4: For maximum performance make sure sealant is at room temp and not below 40°F (4°C). Step 5: Install sealant within the annular space to the desired depth using an appropriate 20-ounce caulking gun dispenser. Determine bead size and cut the end of tip to the desired width. Install around penetrating item(s) flush to substrate surface. Step 6: Tool the sealant with a clean damp knife or trowel. Step 7: When finished, clean all tools promptly with water. Seal any unused material to prevent pre-mature curing in container.
- **Warranty:** HOLDRITE HydroFlame offers a limited 2-year warranty on all firestop products free from defects in material and workmanship. Please see HOLDRITE website www.holdrite.com for complete and official warranty information.
- For technical information please call (877) 700-4242 or visit our website (www.holdrite.com).

PRODUCT SPECIFICATION SHEET

HoldRite® HydroFlame™ 100 Sealant



HydroFlame 100 is an elastomeric water based single component non-sag low-intumescent firestop sealant. It is convenient in areas and conditions where dynamic movement is expected. An ideal firestop sealant for new and existing penetrations through interior rated gypsum, concrete, and block walls as well as rated concrete floors, concrete over metal decking floors, and wood floor-ceiling assemblies. When properly installed, HydroFlame 100 will prevent the passage of smoke, gasses, and flames through openings around penetrating items. HydroFlame 100 is ready to be dispensed out of the package and does not require thinning or mixing. It is simple to install and can be dispensed out of any standard caulking gun or bulk loader that is designed for 10, 20, or 30-ounce packaging as well as 5-gallon buckets. Additionally, it can easily be troweled out of a 5-gallon bucket. HydroFlame 100 UL systems are rated up to 4 hours as tested in conformance to ASTM E 814 or ANSI/UL-1479, and CAN/ULC-S115.

Product information:

- Material Properties:** HydroFlame 100 sealant does not contain any solvents, asbestos fillers or hazardous materials. Application temp 40°F (4°C) - 120°F (49°C). Cure Time: 3-4 weeks at 77°F (25°C). Density: 12.5 +/- 0.5 lbs./gal. (1.25 kg/L). Skin over time: 30 minutes 77°F (25°C). Product color RED. Elastomeric and flexible. PH Value 7 - 8. Density 12.5 +/- 0.5 lbs./gal. Freeze/thaw -- exceptional. VOC Negligible. Volume coverage: 10.3 oz. cartridge = 304ml, 18 cu. in., or 295cc. Volume coverage: 5-gallon buckets = 1155 cubic inches or 5,000 cu. cm/L.
- Application:** HydroFlame 100 sealant when properly installed will prevent the passage and migration of smoke, toxic gases, and flames through wall and floor assemblies where penetration firestop systems are installed. Can be used on a variety of combustible plastic and noncombustible pipes or insulated pipes including PVC, CPVC, ABS and PVDF cross-linked Polyethylene (PEX) tubing. steel, copper, cast iron, EMT and communication/telephone cables and more. HydroFlame 100 is a flexible firestop sealant so it can be used in areas where vibrations or other movements occur. In addition, it has excellent sound attributes and can be used where rated walls or floors have high STC requirements.
- Availability:** HydroFlame 100 is available in the following four sizes: 10.3oz. cartridges (304ml), 20.2oz. sausages (597ml), 30oz. cartridges (887ml), and 5-gallon buckets (18.9L).

Product Submittal

Job Name:	
Date:	
Part Number:	Qty:
Architect / Owner:	
Contractor:	
Notes:	



Buy American Act



MEMBER

THIS INFORMATION IS PROPRIETARY TO HOLDRITE AND IS SUBJECT TO CHANGE WITHOUT NOTICE. IT MAY NOT BE REPRODUCED IN PART OR WHOLE WITHOUT WRITTEN AUTHORIZATION.



800-321-0316 OR 760-744-6944 / FAX: 760-744-0507 / WWW.HOLDRITE.COM
spec_HFP Series, HydroFlame 100, RevB, 12-04-19
Page 1 of 2



- **Limitations:** HydroFlame 100 should not be used in areas exposed to exterior applications where UV exposure is present. HydroFlame 100 should not be used in areas exposed to excessive moisture or is constantly wet. It should not be used in places where standing water is present. In addition, HydroFlame 100 should not be used on extremely hot uninsulated penetrations or on surfaces that will be excessively hot above 300°F (149°C).
- **Storage & Handling:** HydroFlame 100 should be stored between 35°F (2°C) and 120°F (49°C) to obtain a 3-year shelf life, subject to inspection. NOTE: Do not dilute, no mixing is required. Best if protected from freezing. If freezing occurs, thaw completely before using. Keep products stored under protective cover in original containers.
- **Testing Data:** For detailed testing data and criteria please refer to UL's (Underwriters Laboratory) Fire Resistance Directory. HydroFlame 100 was tested at positive pressure with a minimum 0.01 (2.5 Pa) inches water and in accordance with ASTM E814 (UL 1479), ASTM E1966 (UL 2079) and CAN/ULC-S115. ASTM G21 Mold resistant. STC rating at 65, (based on ASTM E90 testing on a U411 wall design). ASTM E84 (UL 723 Tunnel Test). Flame Spread = 10. Smoke Index = 0. This product is Clean Air Gold certified.
- **Compatibility:** "FBC™ System Compatible indicates that these products has been tested, and is monitored on an ongoing basis, to assure its chemical compatibility with FlowGuard Gold®, BlazeMaster® and Corzan® piping systems and products made with TempRite® Technology." "The FBC Compatible Logo, FBC™, FlowGuard Gold®, BlazeMaster®, Corzan®, and TempRite® are trademarks of Lubrizol Advanced Materials Inc. or its affiliates."
- **Features:** Flexible (Elastomeric). Low VOC. Paintable. Water based. Excellent freeze-thaw. High STC rating 65. 3-Year shelf life. Low-intumescent FBC™ System Compatible. Easily dispensed (caulking gun or trowel). G21 testing for obstruction of mold growth. This product is Clean Air Gold certified.
- **Installation Data:** Do not thin or mix with water or other liquids. Store product between 35°F (2°C) and 120°F (49°C). Avoid freezing temps and thaw completely if product freezes. Step 1: Create opening in substrate and install penetrating item(s) in accordance with local standards and building codes. Step 2: Choose desired UL drawings to install. Step 3: Clean all wall or floor substrate and penetrant surfaces. Ensure surfaces are free from any dust, debris, wax, oil, moisture and other contaminates. Step 4. Install backing material if required by UL system. Step 5: For maximum performance make sure sealant is at room temp and not below 40°F (4°C). Step 6: Determine bead size and cut the end of the nozzle to the desired width if a standard 10 or 30-ounce cartridge is being used. Use an appropriate 20-ounce caulking gun if the sausage pack is being installed or trowel product into place manually or use an appropriate bulk loading caulking gun dispenser or a trowel if the 5-gallon bucket is used. Install sealant within annular space to UL system required depth. Install around penetrating item(s) flush to substrate surface. Step 7: Tool the sealant with a clean damp knife or trowel. Step 8: When finished, clean all tools promptly with water. Seal any unused material to prevent pre-mature curing in container.
- **Warranty:** HOLDRITE HydroFlame offers a limited 2-year warranty on all firestop products free from defects in material and workmanship. Please see HOLDRITE website www.holdrite.com for complete and official warranty information.
- For technical information please call (877) 700-4242 or visit our website (www.holdrite.com).

SAFETY DATA SHEET



HydroFlame® 100

General purpose firestop sealant

Section 1 – Product and Company Information

Product Name	HydroFlame® 100	HMIS Codes	
Product Codes	HF100-10C, HF100-20S, HF100-30C, HF100-5B	Health	1
Chemical Family	Organic/Inorganic	Flammability	0
Use	Firestopping Material	Reactivity	0
Manufacturer's Name	Reliance Worldwide Corporation (RWC) 2300 Defoor Hills Rd. Atlanta, GA 30318 USA	PPI	B
Date of Validation	December 11, 2018	Emergency Telephone No.	Chemtrec 24 Hours (800)-424-9300 USA (703)-527-3887 International
Date of Preparation	December 11, 2018	Technical Service Telephone No.	(877) 700-4242

Section 2 – Hazards Identification

GHS CLASSIFICATION

Physical Hazards:

None

Health Hazards

Acute Toxicity:

- Oral: Not Classified
- Dermal: Not Classified
- Inhalation: Not Classified
- Skin Corrosion/Irritation: Not Classified
- Serious Eye Damage/Eye Irritation: Not Classified
- Respiratory or Skin Sensitization: Not Classified
- Germ Cell Mutagenicity: Not Classified
- Carcinogenicity: Not Classified
- Reproductive Toxicology: Not Classified
- Target Organ Systemic Toxicity - Single Exposure: Not Classified
- Target Organ Systemic Toxicity - Repeated Exposure: Not Classified

Aspiration Toxicity: Not Classified

ENVIRONMENTAL HAZARDS

Hazardous to the Aquatic Environment: Not Classified
Acute aquatic toxicity: Not Classified
Chronic aquatic toxicity: Not Classified
Bioaccumulation potential: Not Classified
Rapid degradability: Not Classified

GHS Label elements, including precautionary statements

Pictogram: None

Signal Word: None

Hazard Statements:
None

Precautionary Statements:
P102 - Keep out of reach of children.
P264 - Wash hands thoroughly after handling.

Classification according to EU Directives 67/548/EEC or 1999/45/EC

Labeling Symbols: None

Risk R-Phrases: None

Safety S-Phrases:
S2: Keep out of the reach of children.

Summary of Acute Hazards

May cause skin irritation.

Route of Exposure, Signs and Symptoms

INHALATION

Not a respiratory irritant.

EYE CONTACT

Contact may cause eye irritation.

SKIN CONTACT

Contact may cause skin irritation.

INGESTION

Possible irritation to mucous membranes of the mouth, throat, and stomach.

SUMMARY OF CHRONIC HAZARDS

None known.

MEDICAL CONDITIONS AGGRAVATED BY EXPOSURE

Persons with pre-existing skin conditions or chemical allergies may be more susceptible to contact effects of the cured elastomer.

Section 3 – Composition/Information on Ingredients

% by WT

CAS No.

INGREDIENT

UNITS

None as defined by OSHA Hazard Communication Standard 29 CFR 1910.1200.

Section 4 – First Aid Measures

- If inhaled: Not a respiratory irritant.
- If on skin: Wash with soap and water. If irritation occurs, seek medical attention.
- If in eyes: Immediately flush with large amounts of water. If irritation occurs, seek medical attention.
- If swallowed: If swallowed, call a physician immediately. Only induce vomiting at the instruction of a physician. Never give anything by mouth to an unconscious person.

Section 5 – Fire Fighting Measures

Flash Point	LEL	UEL
None	N/D	N/D

Extinguishing Media

Foam, dry chemical, carbon dioxide or water fog.

Special Fire Fighting Procedures: Wear self-contained breathing apparatus (SCBA) and other protective clothing. Hazardous decomposition products possible (see Section 10)

Unusual Fire and Explosion Hazards: Fire conditions will activate product causing intumescence to occur.

Section 6 -Accidental Release Measures

Steps to Be Taken in Case Material Is Released or Spilled: Wipe up spills to prevent footing hazard. Avoid flushing into sewers, drains, waterways and soil. Wear protective clothing during clean up.

Section 7 – Handling and Storage

Precautions to Be Taken in Handling and Storing: Keep container closed and upright when not in use. To prevent freezing and possible rupture of container, do not store below 35 F.

Other Precautions: Avoid prolonged or repeated contact with skin or clothing. Empty containers may contain residues and vapors; treat as if full and observe all product precautions. Do not reuse empty containers. KEEP OUT OF REACH OF CHILDREN.

Section 8 – Exposure Controls/Personal Protection

Respiratory Protection (Specify Type): None required.

Ventilation – Local Exhaust: Acceptable

Special: N/A

Mechanical (General): Preferable

Other: N/A

Protective Gloves: Wear rubber gloves.

Eye Protection: Safety glasses (ANSI Z-87.1 or equivalent)

Other Protective Clothing or Equipment: Coveralls recommended.

Work/Hygienic Practices: Where sue can result in skin contact, wash exposed areas thoroughly before eating, drinking, smoking or leaving work area. Launder contaminated clothing before reuse.

Section 9 – Physical and Chemical Properties

Boiling point:	212 F (100C) @ 760mm HG
Specific gravity (H ₂ O = 1):	1.5
Vapor pressure (mmHg):	17 @ 68 F (20 C)
Melting point:	N/A
Vapor Density (Air = 1):	N/A
Evaporation rate (Ethyl Acetate = 1):	>1
Appearance/Odor:	Red paste/Mild odor
Solubility in water:	Soluble
Volatile Organic Compounds (VOC) Content (theoretical percentage by weight):	< 1% or (< 10 g/L)
Flash point:	None
Lower explosion limit:	None
Upper explosion limit:	None

Section 10 – Stability and Reactivity

Stability: Stable

Conditions to Avoid: None.

Incompatibility (Materials to Avoid): None known.

Hazardous Decomposition Products: CO, CO₂ and fragmented hydrocarbons.

Hazardous Polymerization: Will not occur.

Section 11 – Toxicology Information

Chronic Health Hazards

No ingredient in this product is an IARC, NTP or OSHA Lister carcinogen.

Toxicology Data

Ingredient Name

None

Section 12 - Ecological Information

Ecological Data

Ingredient Name:	None
Food Chain Concentration Potential:	N/A
Waterfowl Toxicity:	N/A
BOD:	N/A
Aquatic Toxicity:	N/A

Section 13 – Disposal Considerations

Waste Classification: Non-regulated solid waste

Disposal Method: Approved landfill

Waste from this product is not considered hazardous as defined under the Resource Conservation and Recovery Act (RCRA) 40 CFR 261. Dispose of in accordance with federal, state, and local regulation regarding pollution.

Section 14 – Transportation Information

DOT:	Non-regulated
Ocean (IMDG):	Non-regulated
Air (IATA):	Non-regulated
WHMIS (Canada):	Non-regulated

Section 15 – Regulatory Information

Regulatory Data

Ingredient Name:	None
SARA 313	N/A
TSCA Inventory	All components listed
CERCLA RQ	N/A
RCRA Code	N/A

Section 16 -Other Information

This document is prepared pursuant to the OSHA Hazard Communication Standard (29 CFR 1910.1200). The information herein is given in good faith, but no warranty, expressed or implied is made.

Consult Reliance Worldwide Corporation (RWC) for further information: (877) 700-4242