

XHEZ.F-C-2485 - THROUGH-PENETRATION FIRESTOP SYSTEMS

Design/System/Construction/Assembly Usage Disclaimer

- Authorities Having Jurisdiction should be consulted in all cases as to the particular requirements covering the installation and use of UL Certified products, equipment, system, devices, and materials.
- Authorities Having Jurisdiction should be consulted before construction.
- Fire resistance assemblies and products are developed by the design submitter and have been investigated by UL for compliance with applicable requirements. The published information cannot always address every construction nuance encountered in the field.
- When field issues arise, it is recommended the first contact for assistance be the technical service staff provided by the product manufacturer noted for the design. Users of fire resistance assemblies are advised to consult the general Guide Information for each product category and each group of assemblies. The Guide Information includes specifics concerning alternate materials and alternate methods of construction.
- Only products which bear UL's Mark are considered Certified.

XHEZ - Through-penetration Firestop Systems

See General Information for Through-penetration Firestop Systems

System No. F-C-2485

May 15, 2019

F Ratings — 1 and 2 Hr (See Item 2)

T Ratings — 0 and 2 Hr (See Item 2)

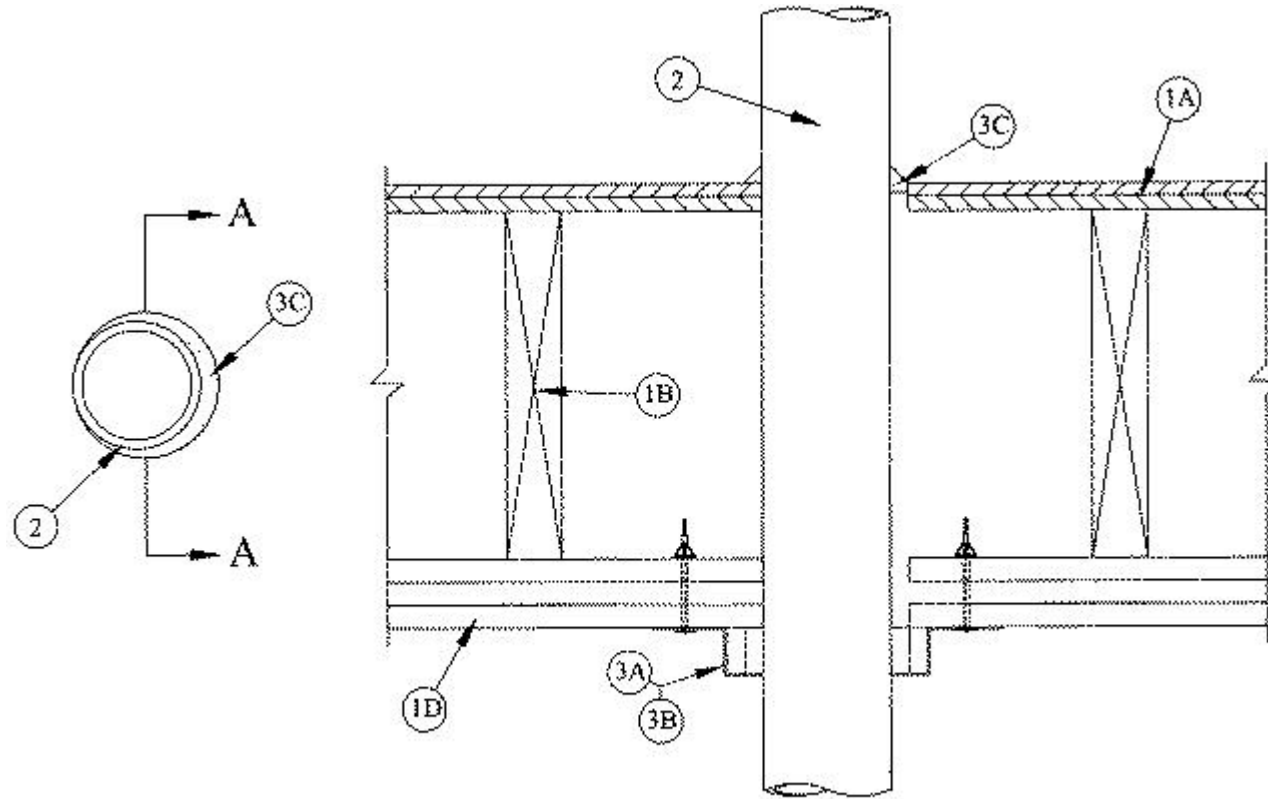

SECTION A-A

1. **Floor Ceiling Assembly** — The 1 hr fire-rated solid or trussed lumber joist floor-ceiling assembly shall be constructed of the materials and in the manner specified in the individual L500 Series Floor-Ceiling Designs in the UL Fire Resistance Directory. The 2 hr fire-rated wood joist floor-ceiling assembly shall be constructed of the materials and in the manner specified in Design Nos. L505, L511 or L536 in the UL Fire Resistance Directory.

A. **Flooring System** — Lumber or plywood subfloor with finish floor of lumber, plywood or **Floor Topping Mixture*** as specified in the individual Floor-Ceiling Design. Max diam of floor opening is 5 in. (127 mm).

B. **Wood Joists** — For 1 hr fire-rated floor-ceiling assemblies nom 10 in. (254 mm) deep (or deeper) lumber, steel or combination lumber and steel joists, trusses or **Structural Wood Members*** with bridging as required and with ends firestopped. For 2 hr fire-rated floor-ceiling assemblies, nom 2 by 10 in. (51 by 254 mm) lumber joists spaced 16 in. (406 mm) OC with nom 1 by 3 in. (29 by 76 mm) lumber bridging and with ends firestopped.

C. **Furring Channels** — (Not Shown) — In 2 hr fire-rated assemblies, resilient galv steel furring installed perpendicular to wood joists between first and second layers of gypsum board (Item 1D). Furring channels spaced max 24 in. (76 mm) OC. In 1 hr fire-rated assemblies, resilient galv steel furring installed perpendicular to wood joists between gypsum board and wood joists as specified in the individual Floor-Ceiling Design. Furring channels spaced max 24 in. (76 mm) OC.

D. **Gypsum Board*** — Nom 4 ft wide by 5/8 in. (1.2 m by 16 mm) thick as specified in the individual Floor-Ceiling Design. First layer of gypsum board secured to wood joists or furring channels as specified in the individual Floor-Ceiling Design. Second layer of gypsum board (2 hr fire-rated assembly) screw-attached to furring channels as specified in the individual Floor-Ceiling Design. Max diam of ceiling opening is 5 in.

The F and T Ratings of the firestop system are dependent upon the to the hourly fire rating of the floor-ceiling assembly and the type of through penetrant as shown in Item 2.

1.1. **Chase Wall** — (Not Shown, Optional) — The through penetrants (Item 2) may be routed through a 1 or 2 hr fire-rated single, double or staggered wood stud/gypsum board chase wall having a fire rating consistent with that of the floor-ceiling assembly. The chase wall shall be constructed of the materials and in the manner specified in the individual U300 Series Wall and Partition Designs in the UL Fire Resistance Directory and shall include the following construction features:

A. **Studs** — Nom 2 by 6 in. (51 by 152 mm) lumber or double nom 2 by 4 in. (51 by 102 mm) lumber studs.

B. **Sole Plate** — Nom 2 by 6 in. (51 by 152 mm) lumber or parallel 2 by 4 in. (51 by 102 mm) lumber plates, tightly butted.

C. **Top Plate** — The double top plate shall consist of two nom 2 by 4 in. (51 by 102 mm) lumber plates or two sets of nom 2 by 4 in. (51 by 102 mm) lumber plates tightly butted. Max diam of opening is 5 in. (127 mm)

D. **Gypsum Board*** — Thickness, type number or layers and fasteners shall be as specified in individual Wall and Partition Designs.

2. **Through Penetrants** — One nonmetallic pipe or conduit to be installed either concentrically or eccentrically within the firestop system. The space between pipe or conduit and periphery of opening shall be min 0 in. (point contact) to max 1/2 in. (13 mm). Pipe or conduit to be rigidly supported on both sides of floor-ceiling assembly. The following types and sizes of nonmetallic pipes or conduits may be used:

A. **Polyvinyl Chloride (PVC) Pipe** — Nom 4 in. (102 mm) diam (or smaller) Schedule 40 cellular or solid core PVC pipe for use in closed (process or supply) or vented (drain, waste or vent) piping systems.

B. **Rigid Nonmetallic Conduit+** — Nom 4 in. (102 mm) diam (or smaller) Schedule 40 PVC conduit installed in accordance with Article 347 of the National Electrical Code (NFPA No. 70).

C. **Chlorinated Polyvinyl Chloride (CPVC) Pipe** — Nom 4 in. (102 mm) diam (or smaller) SDR 13.5 CPVC pipe for use in closed (process or supply) piping systems.

D. **Acrylonitrile Butadiene Styrene (ABS) Pipe** — Nom 4 in. (102 mm) diam Schedule 40 cellular or solid core ABS pipe for use in closed (process or supply) or vented (drain, waste or vent) piping systems.

The F and T Ratings of the firestop system are dependent upon the hourly fire rating of the floor-ceiling assembly and the type of through penetrant as shown in the table below:

Assembly rating, Hr	Type of Penetrant	F Rating, Hr	T Rating, Hr
2	ABS pipe	2	2
2	PVC pipe, RNC or CPVC pipe	2	0
1	ABS pipe	1	1
1	PVC pipe, RNC or CPVC pipe	1	0

3. **Firestop System** — The firestop system shall consist of the following:

A. **Fill, Void or Cavity Material* — Wrap Strip** — Nom 1/4 in. (6 mm) thick intumescent material faced on both sides with a plastic film, supplied in 1 in. (25 mm) wide strips. Two layers of wrap strips are individually wrapped around the through-penetrant with the ends butted and held in place with masking tape. Butted ends in successive layers shall be offset or aligned. The wrap strips are wrapped around through-penetrant on underside of gypsum board ceiling.

RELIANCE WORLDWIDE CORPORATION DBA HOLDRITE HYDROFLAME — HydroFlame Wrap Strip

B. **Steel Collar** — Collar fabricated from coils of precut 0.018 in. (.46 mm) thick (28 MSG) galv sheet steel available from wrap strip manufacturer. Collar shall be nom 1 in. (25 mm) deep with min four 1 in. (25 mm) wide by 2 in. (51 mm) long anchor tabs for securement to underside of ceiling. Retainer tabs, 3/4 in. (19 mm) wide tapering down to 1/4 in. (6 mm) wide and located opposite the anchor tabs, are folded 90 degrees toward through-penetrant surface to maintain the annular space around the through-penetrant and to retain the wrap strips. Steel collar wrapped around wrap strips and through-penetrant with a 1-1/2 in. (38 mm) wide overlap along its perimeter joint and secured together by means of a min 1/2 in. (13 mm) wide by 0.028 in. thick stainless steel hose clamp installed at midheight of the collar. Collar secured to ceiling at each anchor tab with 3/16 in. (21 mm) diam by min 3 in. (76 mm) long toggle bolts in conjunction with min 1/4 in. (6 mm) by 1-1/4 in. (32 mm) diam steel fender washers.

C. **Fill, Void or Cavity material* — Sealant** — Min 1/4 in. (6 mm) thickness of fill material applied within the annulus, flush with the top surface of the floor or sole plate. At point contact, min 3/8 in. (10 mm) diam bead of fill material applied at penetrant/floor or sole plate interface.

RELIANCE WORLDWIDE CORPORATION DBA HOLDRITE HYDROFLAME — HydroFlame 200

+Bearing the UL Listing Mark

*Bearing the UL Classification Mark

Last Updated on 2019-05-15

The appearance of a company's name or product in this database does not in itself assure that products so identified have been manufactured under UL's Follow-Up Service. Only those products bearing the UL Mark should be considered to be Certified and covered under UL's Follow-Up Service. Always look for the Mark on the product.

UL permits the reproduction of the material contained in the Online Certification Directory subject to the following conditions: 1. The Guide Information, Assemblies, Constructions, Designs, Systems, and/or Certifications (files) must be presented in their entirety and in a non-misleading manner, without any manipulation of the data (or drawings). 2. The statement "Reprinted from the Online Certifications Directory with permission from UL" must appear adjacent to the extracted material. In addition, the reprinted material must include a copyright notice in the following format: "© 2019 UL LLC"