

XHEZ.F-C-2486 - THROUGH-PENETRATION FIRESTOP SYSTEMS

Design/System/Construction/Assembly Usage Disclaimer

- Authorities Having Jurisdiction should be consulted in all cases as to the particular requirements covering the installation and use of UL Certified products, equipment, system, devices, and materials.
- Authorities Having Jurisdiction should be consulted before construction.
- Fire resistance assemblies and products are developed by the design submitter and have been investigated by UL for compliance with applicable requirements. The published information cannot always address every construction nuance encountered in the field.
- When field issues arise, it is recommended the first contact for assistance be the technical service staff provided by the product manufacturer noted for the design. Users of fire resistance assemblies are advised to consult the general Guide Information for each product category and each group of assemblies. The Guide Information includes specifics concerning alternate materials and alternate methods of construction.
- Only products which bear UL's Mark are considered Certified.

XHEZ - Through-penetration Firestop Systems

See General Information for Through-penetration Firestop Systems

System No. F-C-2486

May 15, 2019

F Ratings — 1 and 2 Hr (See Item 3)

T Ratings — 1 and 2 Hr (See Item 3)

L Rating at Ambient - Less than 1 CFM/sq ft

L Rating at 400°F - Less than 1 CFM/sq ft

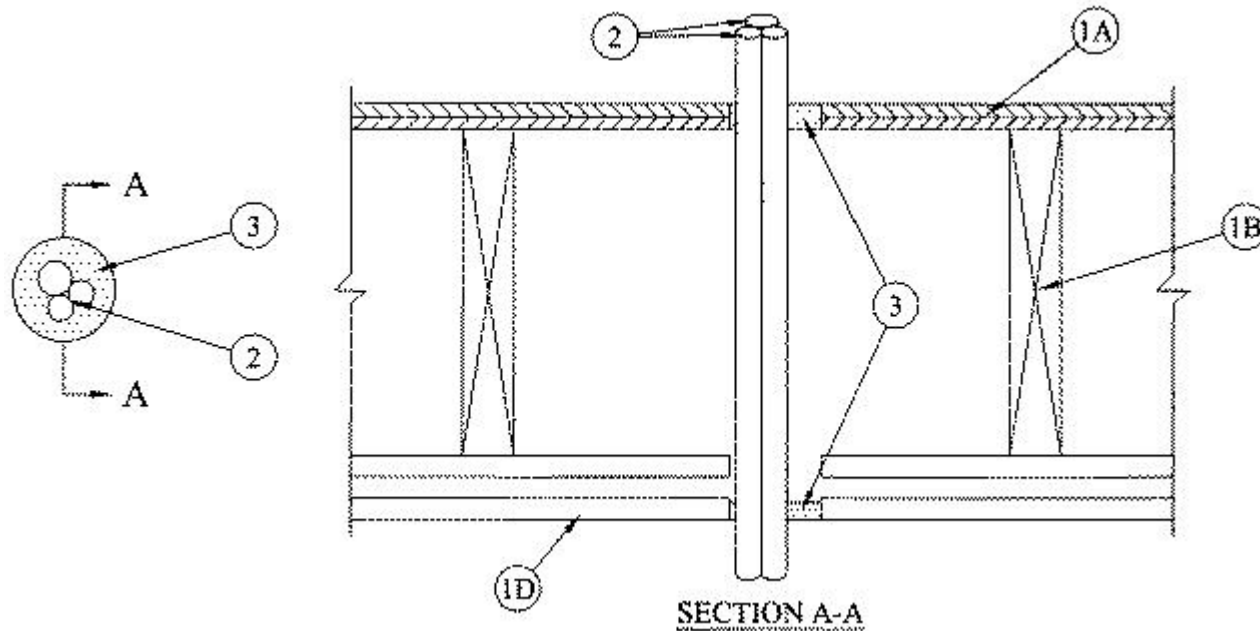

1. **Floor-Ceiling Assembly** — The 1 hr fire-rated solid or trussed lumber joist floor-ceiling assembly shall be constructed of the materials and in the manner specified in the individual L500 Series Floor-Ceiling Designs in the UL Fire Resistance Directory. The 2 hr fire-rated wood joist floor-ceiling assembly shall be constructed of the materials and in the manner specified in Design Nos. L505, L511 or L536 in the UL Fire Resistance Directory. The general construction features of the floor-ceiling assembly are summarized below:

A. **Flooring System** — Lumber or plywood subfloor with finish floor of lumber, plywood or **Floor Topping Mixture*** as specified in the individual Floor-Ceiling Design. Max diam of floor opening is 3 in. (76 mm).

B. **Wood Joists*** — For 1 hr fire-rated floor-ceiling assemblies nom 10 in. (254 mm) deep (or deeper) lumber, steel or combination lumber and steel joists, trusses or **Structural Wood Members*** with bridging as required and with ends firestopped. For 2 hr fire-rated floor-ceiling assemblies, nom 2 by 10 in. (51 by 254 mm) lumber joists spaced 16 in. (406 mm) OC with nom 1 by 3 in. (25 by 76 mm) lumber bridging and with ends firestopped.

C. **Furring Channels** — (Not Shown) — In 2 hr fire-rated assemblies, resilient galv steel furring installed perpendicular to wood joists between first and second layers of gypsum board (Item 1D). Furring channels spaced max 24 in. (610 mm) OC. In 1 hr fire-rated assemblies, resilient galv steel furring installed perpendicular to wood joists between gypsum board and wood joists as specified in the individual Floor-Ceiling Design. Furring channels spaced max 24 in. (610 mm) OC.

D. **Gypsum Board*** — Nom 4 ft (1.2 m) wide by 5/8 in. (16 mm) thick as specified in the individual Floor-Ceiling Design. First layer of gypsum board secured to wood joists or furring channels as specified in the individual Floor-Ceiling Design. Second layer of gypsum board (2 hr fire-rated assembly) screw-attached to furring channels as specified in the individual Floor-Ceiling Design. Max diam of ceiling opening is 3 in. (76 mm).

1.1 **Chase Wall** — (Not Shown, Optional) — The through penetrants (Item 2) may be routed through a 1 or 2 hr fire-rated single, double or staggered wood stud/gypsum board chase wall having a fire rating consistent with that of the floor-ceiling assembly. The chase wall shall be constructed of the materials and in the manner specified in the individual U300 Series Wall and Partition Designs in the UL Fire Resistance Directory and shall include the following construction features:

A. **Studs** — Nom 2 by 6 in. (51 by 152 mm) lumber or double nom 2 by 4 in. (51 by 102 mm) lumber studs.

B. **Sole Plate** — Nom 2 by 6 in. (51 by 152 mm) lumber or parallel 2 by 4 in. (51 by 102 mm) lumber plates, tightly butted. Max diam of opening is 3 in. (76 mm).

C. **Top Plate** — The double top plate shall consist of two nom 2 by 6 in. (51 by 152 mm) lumber plates or two sets of nom 2 by 4 in. (51 by 102 mm) lumber plates tightly butted. Max diam of opening is 3 in. (76 mm).

D. **Gypsum Board*** — Thickness, type, number or layers and fasteners shall be as specified in individual Wall and Partition Designs.

2 **Through Penetrant** — The following types of through penetrants shall be used:

A. **Cross-Linked Polyethylene Tubing** — A max of three SDR 9 (or heavier) cross-linked polyethylene (PEX) tubing for use in closed (process or supply) piping systems. Of the three tubes, a max of one shall have a nom diam greater than 3/4 in. (19 mm). The max diam of one tube is 1 in. (25 mm). The annular space between the tubing and the periphery of the opening shall be a min 3/16 in. (4.8 mm) and a max of 1 in. (25 mm). The space between the tubing shall be a min 0 in. (point contact) to a max 1/4 in. (6 mm). Tubing to be rigidly supported on both sides of the floor-ceiling assembly.

B. **Aluminum Cross-Linked Polyethylene Tubing** — A max of three nominal 3/4 in. (19 mm) diameter SDR 9 (or heavier) aluminum cross-linked polyethylene (AL PEX) tubing for use in closed (process or supply) piping systems. The annular space between the tubing and the periphery of the opening shall be a min 1/8 in. (3.2 mm) and a max of 1 in. (25 mm). The space between the tubing shall be a min 0 in. (point contact) to a max 1/4 in. (6 mm). Tubing to be rigidly supported on both sides of the floor-ceiling assembly.

3. **Fill, Void or Cavity Material* — Sealant** — Min 3/4 in. (19 mm) thickness of fill material applied flush with annulus on top surface of floor or sole plate. Min 1/2 in. (13 mm) thickness of fill material applied flush with annulus on bottom surface of ceiling or on bottom surface of lower top plate of chase wall assembly. Additional fill material forced within the group of tubing to max extent possible on the top surface of floor or sole plate and bottom surface of ceiling or on bottom surface of lower plate of chase wall assembly.

The hourly F and T Ratings of the firestop system are dependent upon the hourly rating of the floor-ceiling assembly in which it is installed, type of through penetrant and type of fill material as shown in the table below:

| Rating of Assembly, Hr | Type of Through Penetrant | Type of Fill Material | F Rating, Hr | T Rating, Hr |
|------------------------|---------------------------|-----------------------|--------------|--------------|
| 1 | PEX | HydroFlame 200 | 1 | 1 |
| 2 | PEX | HydroFlame 200 | 2 | 2 |

RELIANCE WORLDWIDE CORPORATION DBA HOLDRITE HYDROFLAME — HydroFlame 200

*** Indicates such products shall bear the UL or cUL Certification Mark for jurisdictions employing the UL or cUL Certification (such as Canada), respectively.**

The appearance of a company's name or product in this database does not in itself assure that products so identified have been manufactured under UL's Follow-Up Service. Only those products bearing the UL Mark should be considered to be Certified and covered under UL's Follow-Up Service. Always look for the Mark on the product.

UL permits the reproduction of the material contained in the Online Certification Directory subject to the following conditions: 1. The Guide Information, Assemblies, Constructions, Designs, Systems, and/or Certifications (files) must be presented in their entirety and in a non-misleading manner, without any manipulation of the data (or drawings). 2. The statement "Reprinted from the Online Certifications Directory with permission from UL" must appear adjacent to the extracted material. In addition, the reprinted material must include a copyright notice in the following format:

"© 2019 UL LLC"