

System No. F-C-2518

July 15, 2020

F Rating — 1 Hr

T Rating — 1 Hr

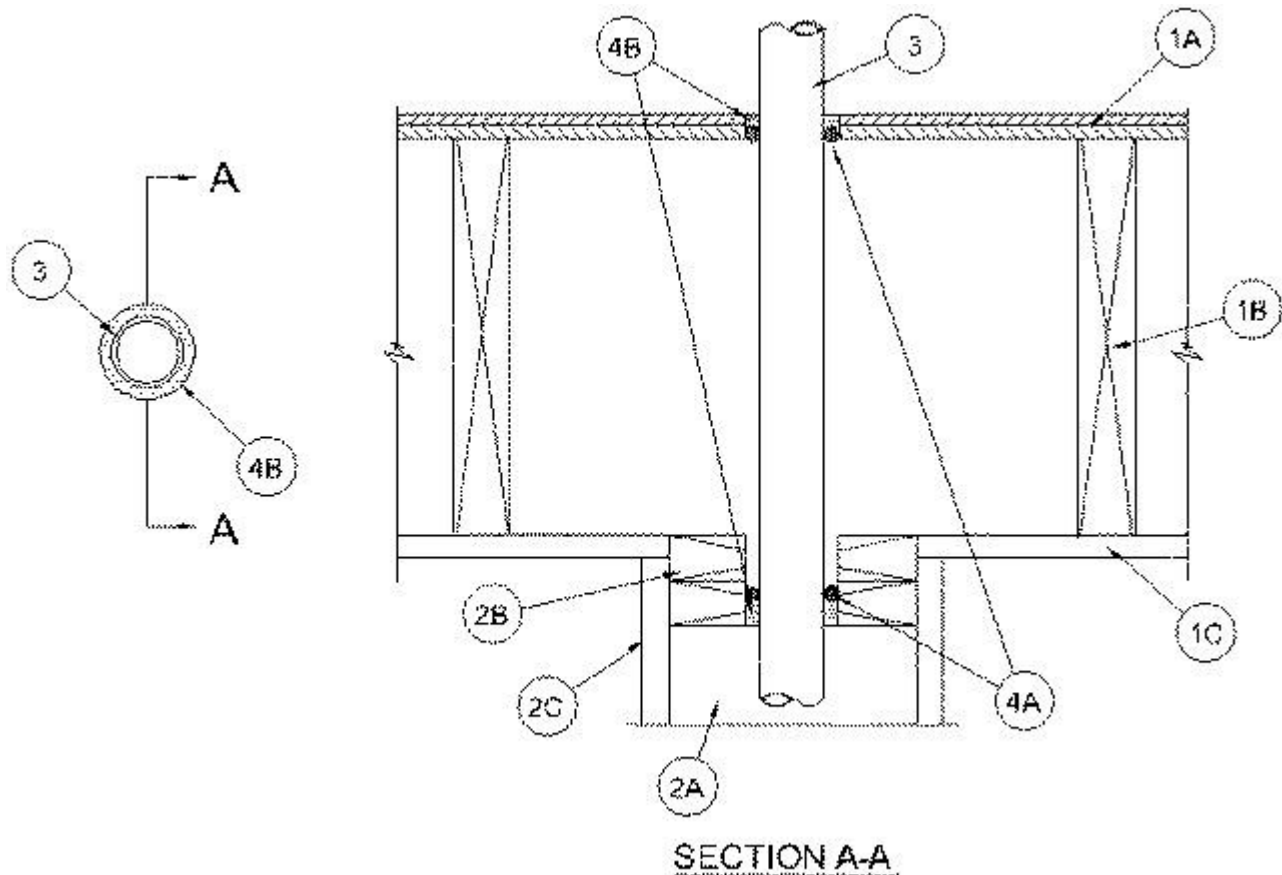

1. **Floor-Ceiling Assembly** — The 1 hr fire-rated wood joist floor-ceiling assembly shall be constructed of the materials and in the manner specified in the individual L500 Designs in the UL Fire Resistance Directory, as summarized below:

A. **Flooring System** — Lumber or plywood subfloor with finish floor of lumber, plywood or **Floor Topping Mixture*** as specified in the individual Floor-Ceiling Design. Max diam of opening is 3 in. (76 mm)

B. **Wood Joists** — Nom 10 in. (254 mm) deep (or deeper) lumber, steel or combination lumber and steel joists, trusses or **Structural Wood Members*** with bridging as required and with ends firestopped.

C. **Gypsum Board*** — Nom 5/8 in. (16 mm) thick as specified in the individual Floor-Ceiling Design

2. **Chase Wall** — The through penetrants (Item 3) shall be routed through a 1 hr fire-rated single, double or staggered wood stud/gypsum board chase wall constructed of the materials and in the manner specified in the individual U300 Series Wall and Partition Designs in the UL Fire Resistance Directory and shall include the following construction features:

A. **Studs** — Nom 2 by 6 in. (51 by 152 mm) lumber or double nom 2 by 4 in. (51 by 102 mm) lumber studs.

B. **Top Plate** — The double top plate shall consist of two nom 2 by 6 in. (51 by 152 mm) lumber plates or two sets of parallel 2 by 4 in. (51 by 102 mm) lumber plates, tightly butted. Max diam of opening is 3 in. (76 mm)

C. **Gypsum Board*** — Thickness, type, number of layers and fasteners shall be as specified in the individual Wall and Partition Design.

3. **Through Penetrant** — One nonmetallic pipe installed concentrically or eccentrically within the firestop system. Diam of circular opening in flooring, and top and sole plates shall be 5/8 to 7/8 in. (16 to 22 mm) larger than the actual diam of pipe such that the annular space is min 0 in. (point contact) to a max. 5/8 in. (16 mm) is required between the penetrant and the periphery of the opening. Pipe to be rigidly supported on each side of the floor assembly. The following types and sizes of nonmetallic pipes may be used:

A. **Polyvinyl Chloride (PVC) Pipe** — Nom 2 in. (51 mm) diam (or smaller) Sch 40 solid or cellular core PVC pipe for use in closed (process or supply) or vented (drain, waste or vent) piping systems.

B. **Composite Cross Linked Polyethylene (PEX-AL-PEX) Pipe** — Nom 1 in (25 mm) diam (or smaller) PEX-AL-PEX pipe for use in closed (process or supply) or vented (drain, waste or vent) piping systems.

C. **Composite Polyethylene (PE-AL-PE) Pipe** — Nom 1 in (25 mm) diam (or smaller) PE-AL-PE pipe for use in closed (process or supply) or vented (drain, waste or vent) piping systems.

D. **Cross Linked Polyethylene (PEX) Pipe** — Nom 1 in (25 mm) diam (or smaller) PEX pipe for use in closed (process or supply) piping systems.

E. **Chlorinated Polyvinyl Chloride (CPVC) Pipe** — Nom 2 in. diam (or smaller) ADR 13.5 CPVC pipe for use in closed (process or supply) piping systems.

F. **Rigid Non-Metallic Conduit +** — Nom 2 in. (51 mm) Diam (or smaller) PVC conduit installed in accordance with Article 347 of the National Electrical Code (NFPA 70).

G. **Electrical Nonmetallic Tubing+** — Nom 2 in. (51 mm) (or smaller) PVC tubing installed in accordance with the National Electrical Code (NFPA 70).

4. **Firestop System** — The firestop system shall consist of the following:

A. **Packing Material** — Foam backer rod firmly packed into opening as a permanent form. Packing material to be recessed from top surface of subfloor and bottom surface of the lower top plate as required to accommodate the required thickness of fill material.

B. **Fill, Void or Cavity Material* - Caulk** — Min 1/4 in. (6 mm) thickness of fill material applied within annulus, flush with top surface of subfloor and min 1/2 in. (13 mm) thickness of fill material applied within the annulus, flush with bottom surface of lower top plate. At point contact location, 1/4 in. (6 mm) diam bead of caulk applied at interface of pipe and periphery of opening on top surface of floor and bottom surface of lower top plate.

RELIANCE WORLDWIDE CORPORATION DBA HOLDRITE HYDROFLAME — HydroFlame 100

* Indicates such products shall bear the UL or cUL Certification Mark for jurisdictions employing the UL or cUL Certification (such as Canada), respectively.

+Bearing the UL Listing Mark

Last Updated on 2020-07-15