

Installation Instructions

For Overhead Electrical Box Support using HOLDRITE Stout Bracket® #SB3 & #SB4

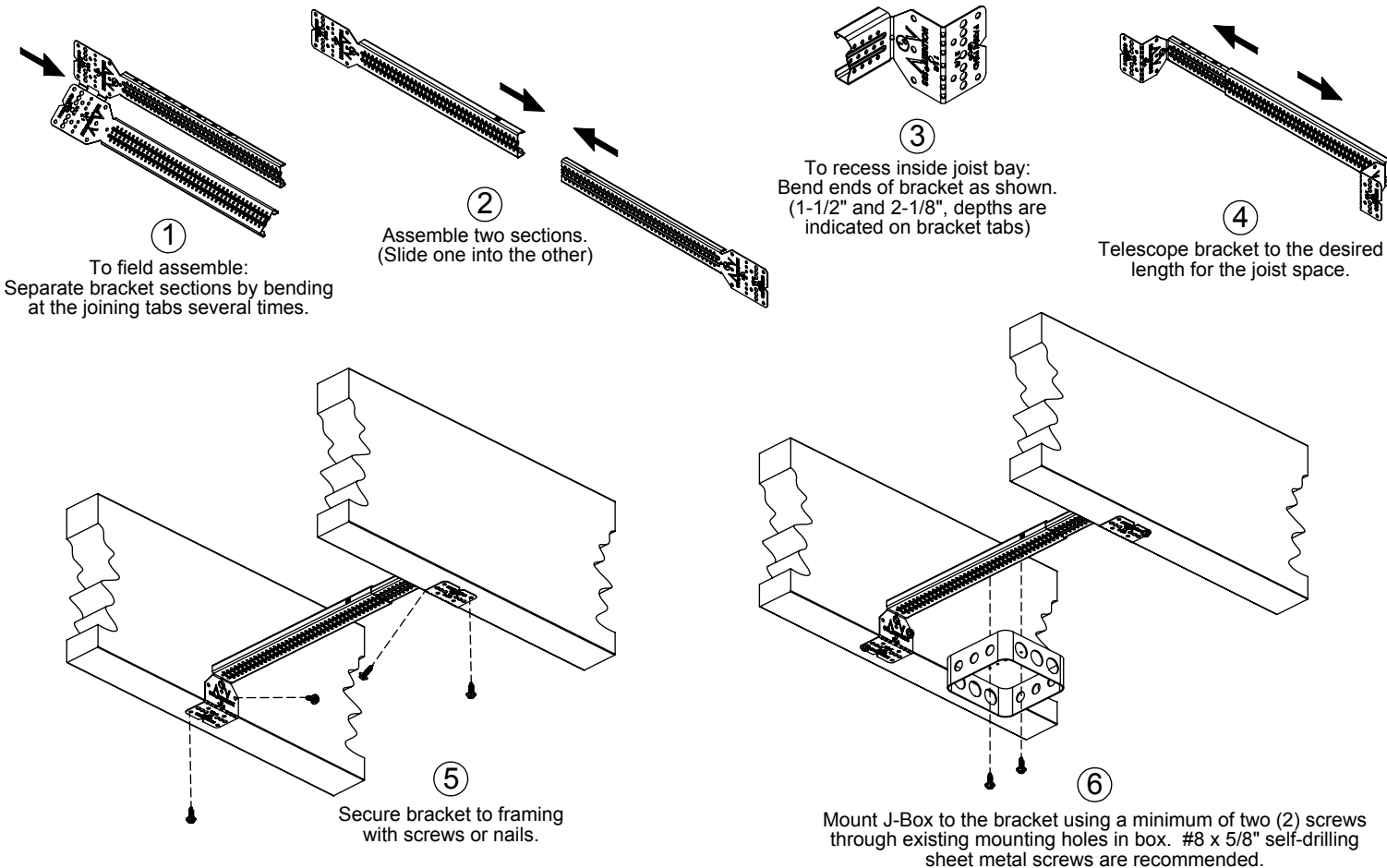

Model #	Description	Joist Bay Spacing	Ideal Recess Depths
SB3	Galvanized Steel Telescoping Bracket	10-1/4" to 16"	1-1/2" or 2-1/8"
SB4	Galvanized Steel Telescoping Bracket	14-1/2" to 24"	1-1/2" or 2-1/8"

WARNING:

- The buyer and/or installer is responsible for:
 - Application in conformance to local codes.
 - The integrity of structures to which the fasteners is attached, including their capability of safely accepting the load imposed, as evaluated by a qualified engineer.
 - Using appropriate industry standard hardware such as sheet metal screws or dry wall screws. #8 x 5/8" self-drilling sheet metal screws are recommended for attaching outlet box to bracket.
- Failure to observe these Instructions may lead to unsatisfactory product performance, which can result in property damage or bodily injury.

SAFETY INSTRUCTIONS: All safety regulations required by the job site must be observed. Special attention should be given to the following instructions. While working on a job site:

- Wear safety glasses with side shields
- Wear gloves to avoid splinters and cuts.
- Be sure power tools are properly grounded.

