

ADJUST TO DESIRED HEIGHT.
(ACCOUNT FOR AERATOR BOX HEIGHT OF 4")
(Fig. 1)

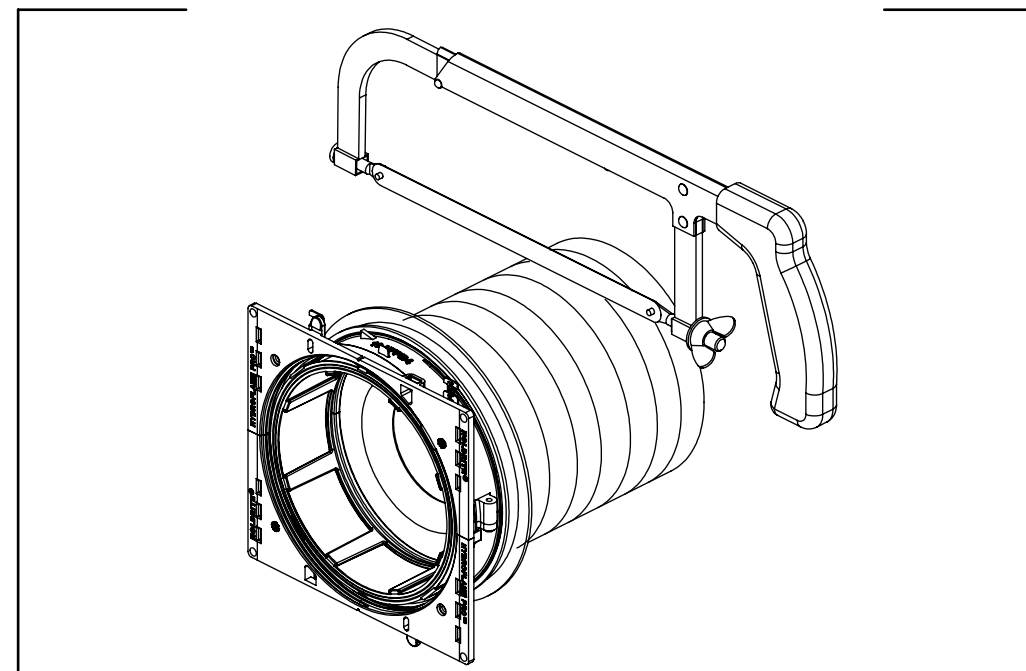

CUT INNER & OUTER SLEEVE
(IF NEEDED).
CAN BE CUT AS SHORT AS 2-1/2".
(Fig. 2)

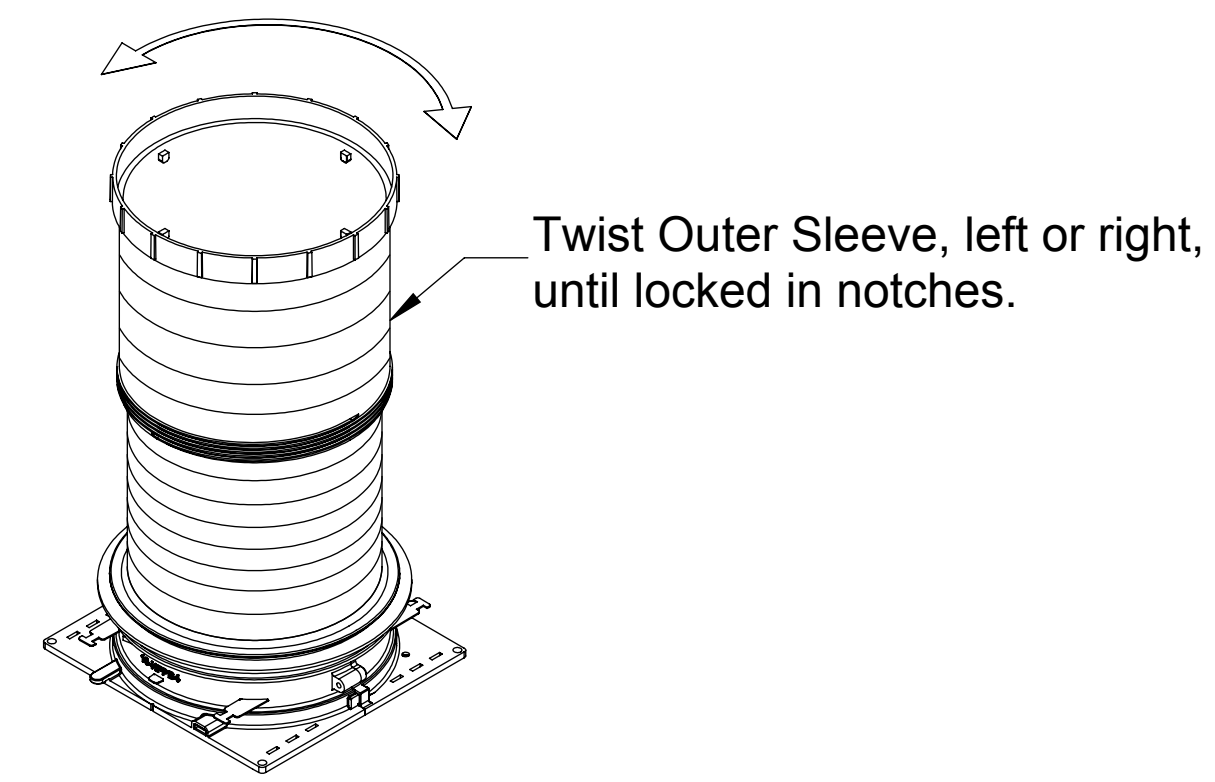

LOCK OUTER SLEEVE IN PLACE.
(Fig. 3)

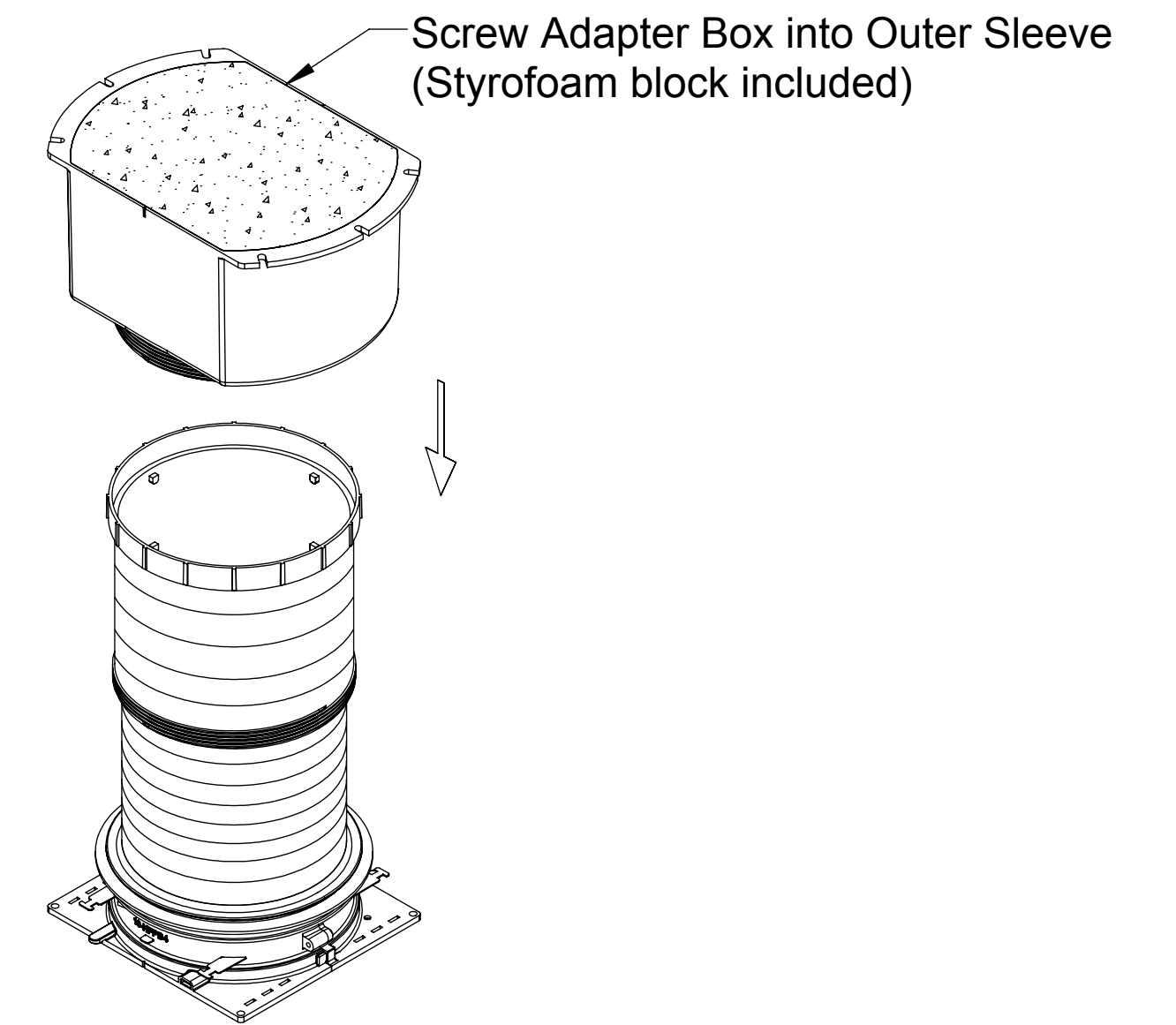

INSTALL AERATOR ADAPTER.
(BOX "INVERTED")
(Fig. 4)

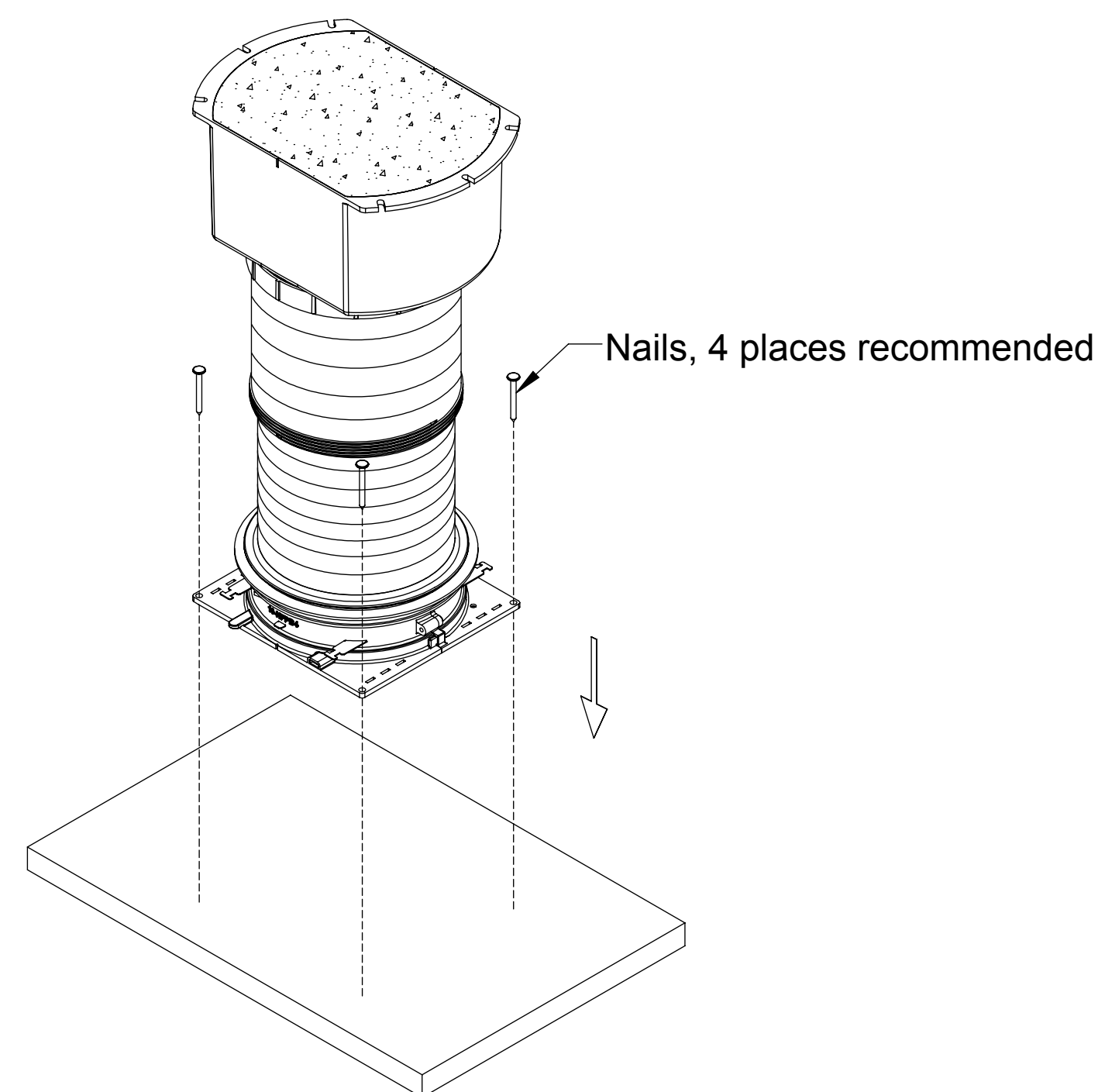

NAIL TO FORM DECK.
(Fig. 5)

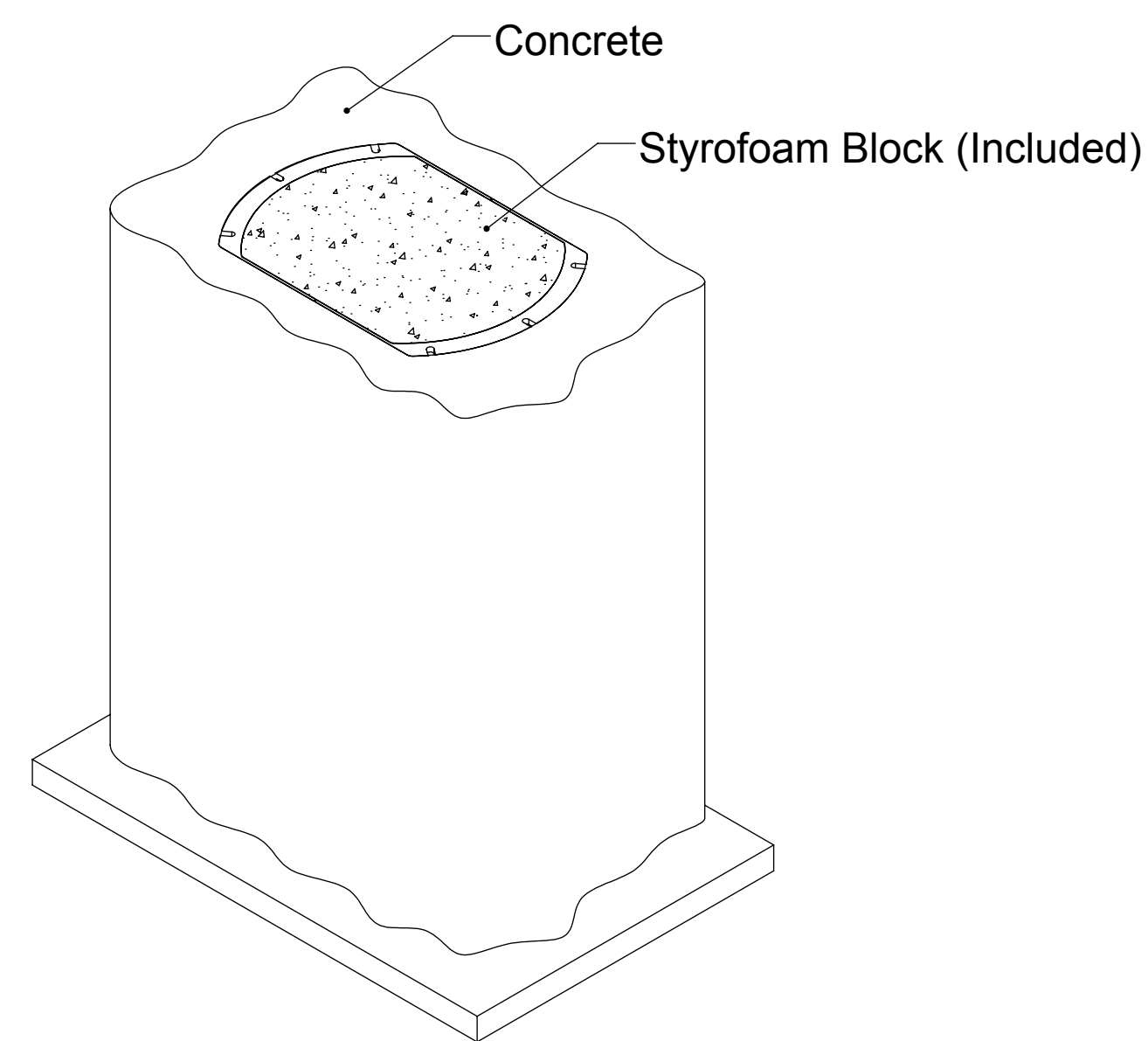

POUR CONCRETE.
(Fig. 6)

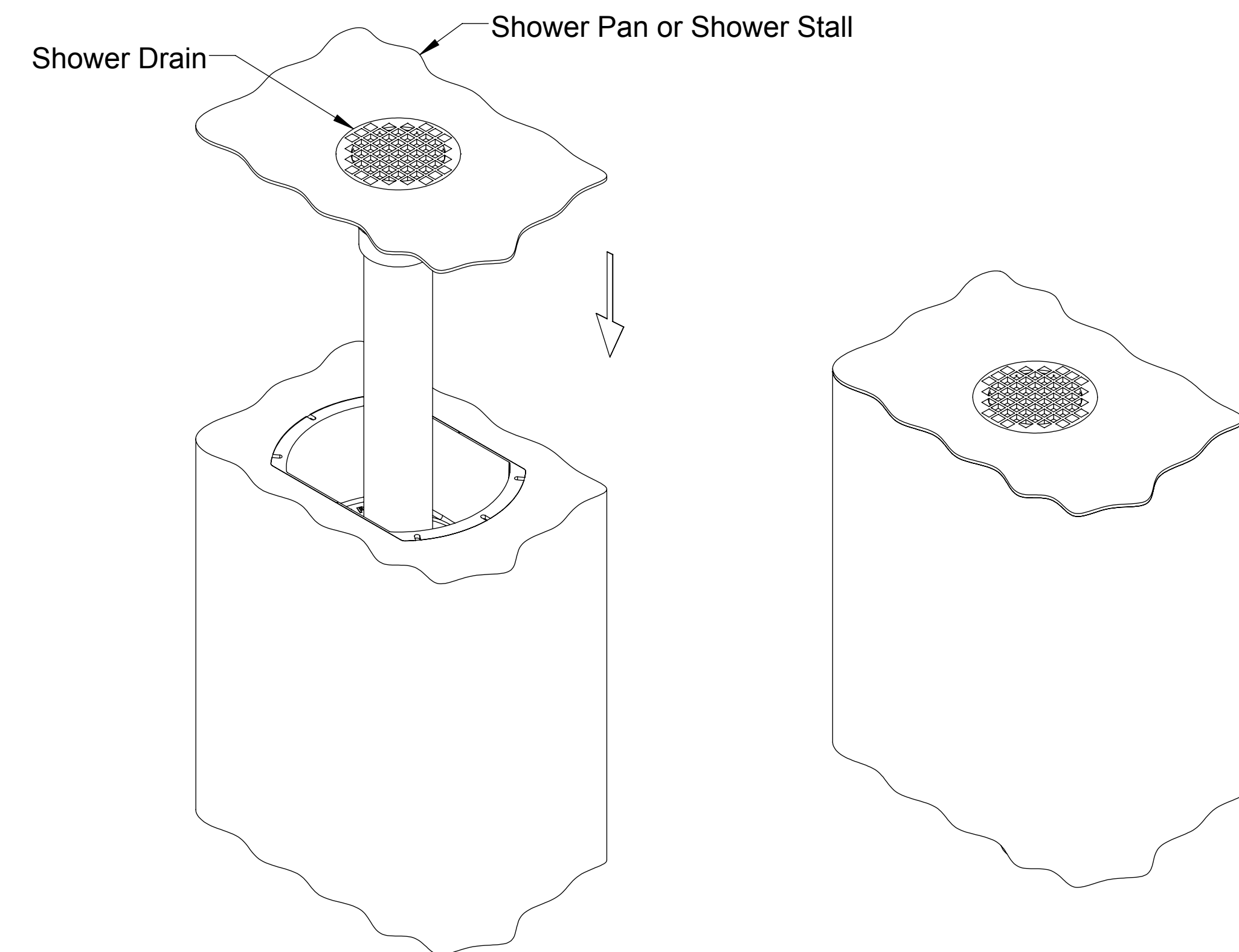

REMOVE STYROFOAM BLOCK AND
INSTALL ASSEMBLED SHOWER PAN OR SHOWER
STALL & SHOWER DRAIN WITH PIPING.
(Fig. 7)