

THROUGH-PENETRATION FIRESTOP SYSTEM

Assembly Usage Disclaimer

Search Parameters

Manufacturer

Holdrite

XHEZ - Through-penetration Firestop Systems

See General Information for Through-penetration Firestop Systems

System No. W-L-2712

January 30, 2019

F Rating — 1 and 2 Hr (See Item 1)

T Ratings — 1 and 1-1/4 Hr (See Item 3)

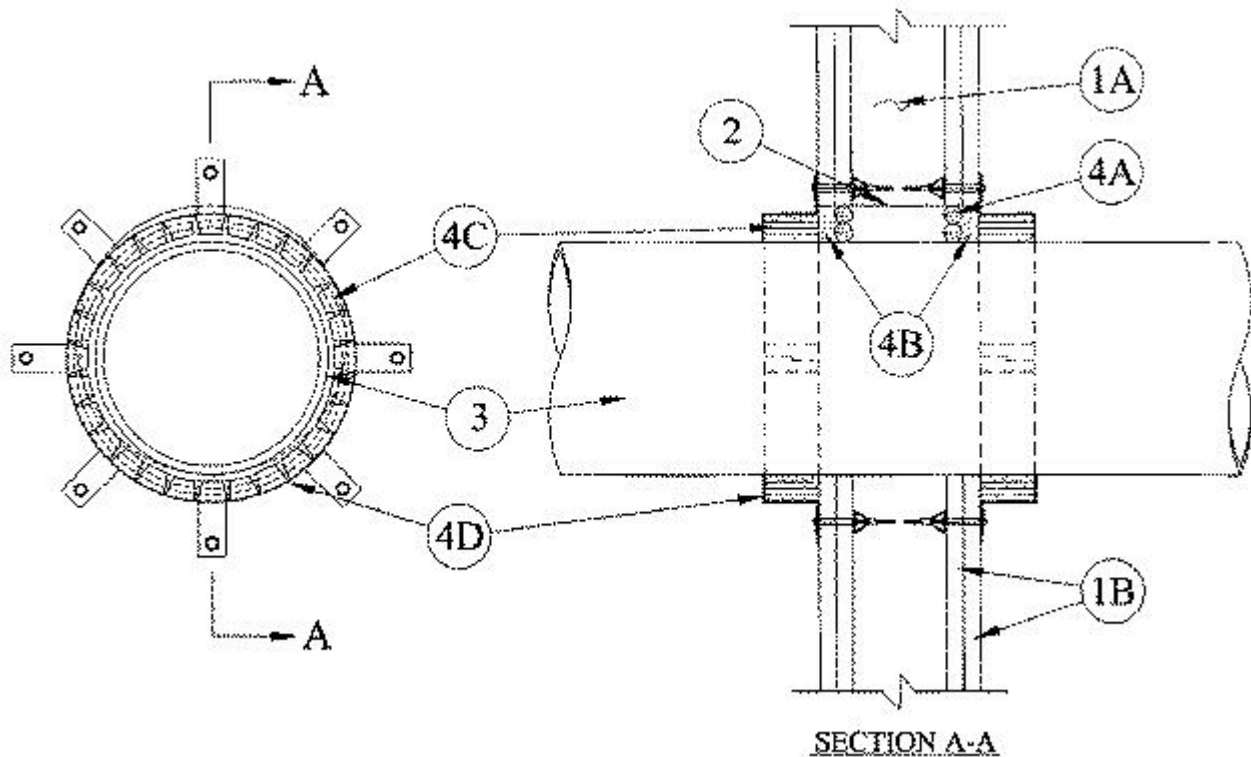

1. **Wall Assembly** — The 1 or 2 hr fire-rated gypsum wallboard/stud wall assembly shall be constructed of the materials and in the manner specified in the individual U300 or U400 Series Wall and Partition Designs in the UL Fire Resistance Directory and shall include the following construction features:

A. **Studs** — Wall framing shall consist of either wood or steel channel studs. Wood studs to consist of nom 2 by 4 in. (51 by 102 mm) lumber spaced 16 in. (406 mm) OC. Steel studs to be min 3-1/2 in. (89 mm) wide and spaced max 24 in. (610 mm) OC.

B. **Gypsum Board*** — Min 5/8 in. (16 mm) thick, 4 ft (1.2 m) wide with square or tapered edges. The gypsum wallboard type, thickness, number of layers and orientation shall be as specified in the individual U300 or U400 Wall and Partition Design. Max diam of opening is 10 in. (254 mm)

The hourly F Rating of the firestop system is equal to the hourly fire rating of the wall assembly in which it is installed.
The hourly T Rating of the firestop system is 1 and 1-1/4 hr when installed in 1 and 2 hr rated walls, respectively.

2. **Steel Wire Mesh** — Cylindrical sleeve fabricated from No. 8 steel wire mesh and having a min 2 in. (51 mm) lap along the longitudinal seam. Length of steel mesh to be 1/2 in. (13 mm) less than thickness of wall. Steel wire mesh to be centered and formed to fit periphery of through opening.

3. **Through Penetrants** — One nonmetallic pipe to be installed either eccentrically or concentrically within the firestop system. The annular space shall be min 0 in. (0 mm) (point contact) to max 1-3/8 in. (35 mm). Pipe to be rigidly supported on both sides of wall assembly. The following types and sizes of nonmetallic pipes may be used:

A. **Polyvinyl Chloride (PVC) Pipe** — Nom 8 in. (203 mm) diam (or smaller) Schedule 40 solid or cellular core PVC pipe for use in closed (process or supply) or vented (drain, waste or vent) piping systems.

B. **Chlorinated Polyvinyl Chloride (CPVC) Pipe** — Nom 8 in. (203 mm) diam (or smaller) SDR 17 CPVC pipe for use in closed (process or supply) or vented (drain, waste or vent) piping systems.

4. **Firestop System** — The firestop system shall consist of the following:

A. **Packing Material** — In 2 hr rated wall assemblies, foam backer rod firmly packed into opening as a permanent form. Packing material to be recessed from both surfaces of wall as required to accommodate the required thickness of fill material.

B. **Fill, Void or Cavity Material* — Caulk** — Min 1/2 in. (13 mm) thickness of fill material applied within the annulus, flush with both surfaces of wall.

RELIANCE WORLDWIDE CORPORATION DBA HOLDRITE
HYDROFLAME — HydroFlame 200

C. Fill, Void or Cavity Material* — Wrap Strip — Nom 1/4 in. (6 mm) thick by 2 in. (51 mm) wide intumescent wrap strip. Four layers of wrap strip are individually wrapped around the through-penetrant with ends butted and held in place with masking tape. Butted ends in successive layer shall be offset. Wrap strip butted tightly against both surface of wall.

**RELIANCE WORLDWIDE CORPORATION DBA HOLDRITE
HYDROFLAME** — HydroFlame Wrap Strip

D. Steel Collar — Collar fabricated from coils of precut min 0.016 in. (.41 mm) thick (No. 28 gauge) galv steel available from fill material manufacturer. Collar shall be nom 2 in. (51 mm) deep with 1 in. (25 mm) wide by 1-1/2 in. (38 mm) long anchor tabs on 4 in. (102 mm) centers for securement to surfaces of wall. In addition, collars contain retainer tabs 1/2 in. (13 mm) wide by 3/4 in. (19 mm) long, located opposite the anchor tabs. Collar shall be wrapped over the wrap strip, overlapping min 1 in. At the overlap, the two ends of the collar shall be transversely slit from opposite directions for a distance of 1-1/2 in. (38 mm), approximately 1/2 in. (13 mm) from the ends, and tucked together. The retainer tabs are folded 90 deg towards the pipe to maintain the annular space around the pipe and to retain the wrap strip. Collar secured to both surfaces of wall at each anchor tab by means of min 1/8 in. diam by 2-1/4 in. (57 mm) long hollow wall anchors in conjunction with 3/16 in. (4.8 mm) by 1/2 in. (13 mm) diam. washers.

*** Indicates such products shall bear the UL or cUL Certification Mark for jurisdictions employing the UL or cUL Certification (such as Canada), respectively.**

Last Updated on 2019-01-30

Design/System/Construction/Assembly Usage Disclaimer

- Authorities Having Jurisdiction should be consulted in all cases as to the particular requirements covering the installation and use of UL Certified products, equipment, system, devices, and materials.
- Authorities Having Jurisdiction should be consulted before construction.
- Fire resistance assemblies and products are developed by the design submitter and have been investigated by UL for compliance with applicable requirements. The published information cannot always address every construction nuance encountered in the field.
- When field issues arise, it is recommended the first contact for assistance be the technical service staff provided by the product manufacturer noted for the design. Users of fire resistance assemblies are advised to consult the general Guide Information for each product category and each group of assemblies. The Guide Information includes specifics concerning alternate materials and alternate methods of construction.

- Only products which bear UL's Mark are considered Certified.

The appearance of a company's name or product in this database does not in itself assure that products so identified have been manufactured under UL's Follow-Up Service. Only those products bearing the UL Mark should be considered to be Certified and covered under UL's Follow-Up Service. Always look for the Mark on the product.

UL permits the reproduction of the material contained in the Online Certification Directory subject to the following conditions: 1. The Guide Information, Assemblies, Constructions, Designs, Systems, and/or Certifications (files) must be presented in their entirety and in a non-misleading manner, without any manipulation of the data (or drawings). 2. The statement "Reprinted from the Online Certifications Directory with permission from UL" must appear adjacent to the extracted material. In addition, the reprinted material must include a copyright notice in the following format: "© 2019 UL LLC".

UL and the UL logo are trademarks of UL LLC © 2019 All Rights Reserved.