

THROUGH-PENETRATION FIRESTOP SYSTEM

Assembly Usage Disclaimer

Search Parameters

Manufacturer

Holdrite

XHEZ - Through-penetration Firestop Systems

XHEZ7 - Through-penetration Firestop Systems Certified for Canada

[See General Information for Through-penetration Firestop Systems](#)

[See General Information for Through-penetration Firestop Systems Certified for Canada](#)

System No. W-L-7285

February 13, 2019

ANSI/UL1479 (ASTM E814)	CAN/ULC S115
F Ratings — 1 and 2 Hr (See Item 1)	F Rating — 1 and 2 Hr (See Item 1)
T Rating — 0 Hr	FT Rating — 0 Hr
L Rating At Ambient — Less Than 1 CFM/sq ft	FH Rating — 1 and 2 Hr (See Item 1)
L Rating At 400°F — Less Than 1 CFM/sq ft	FTH Rating — 0 Hr
	L Rating At Ambient — Less Than 1 CFM/sq ft
	L Rating At 400°F — Less Than 1 CFM/sq ft

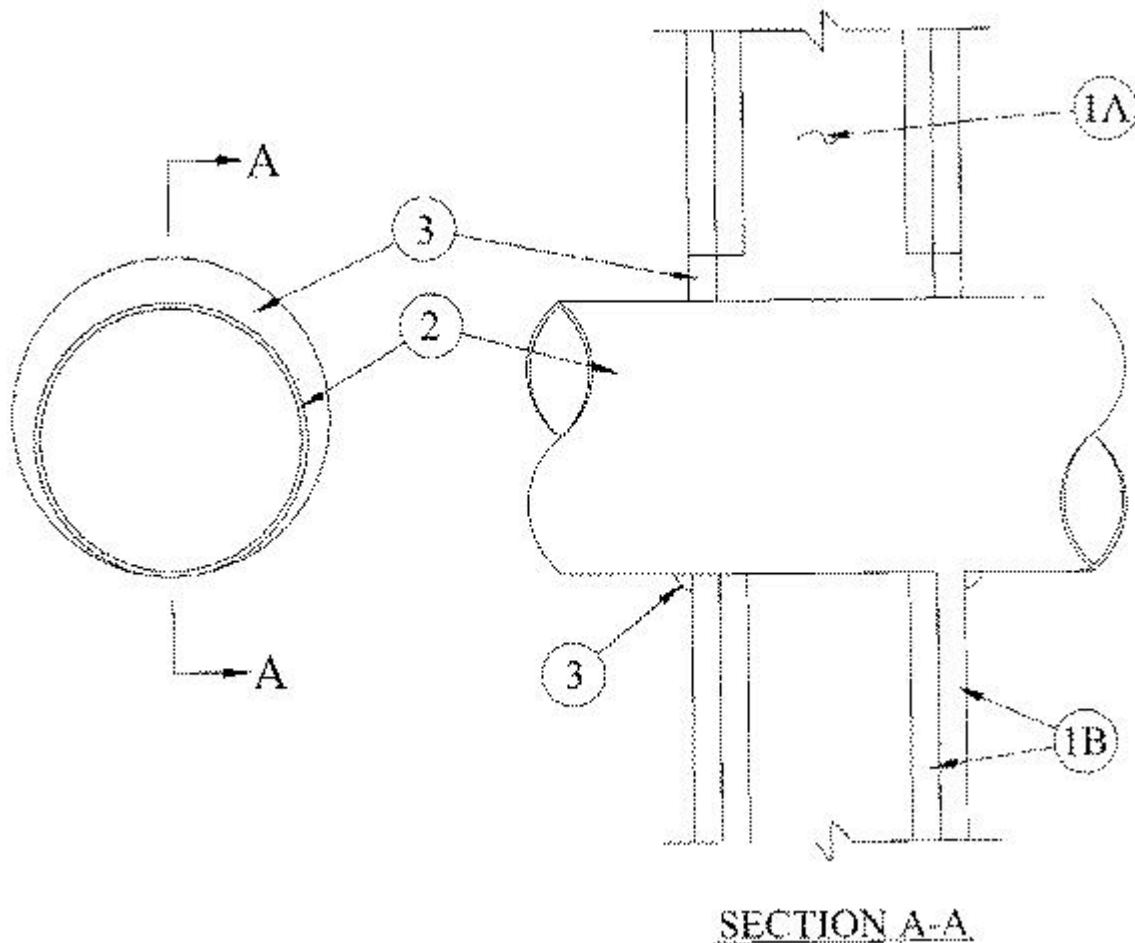

1. **Wall Assembly** — The 1 or 2 hr fire-rated gypsum board/stud wall assembly shall be constructed of the materials and in the manner described in the individual U300, U400, V400 or W400 Series Wall and Partition Design in the UL Fire Resistance Directory and shall include the following construction features:

A. **Studs** — Wall framing may consist of either wood studs or steel channel studs. Wood studs to consist of nom 2 by 4 in. (51 by 102 mm) lumber spaced 16 in. (406 mm) OC with nom 2 by 4 in. (51 by 102 mm) lumber end plates and cross braces. Steel studs to be min 3-5/8 in. (92 mm) wide and spaced max 24 in. (610 mm) OC.

B. **Gypsum Board*** — 5/8 in. (16 mm) thick, 4 ft (1.2 m) wide with square or tapered edges. The gypsum board type, thickness, number of layers, fastener type and sheet orientation shall be as specified in the individual Design in the UL Fire Resistance Directory. Max diam of opening as shown in table below.

The hourly F Rating of the firestop system is equal to the hourly fire rating of the wall assembly in which it is installed.

2. **Through Penetrant** — One nom 4 in. (102 mm) diam (or smaller) No. 30 MSG (or heavier), or one nom 6 in. (152 mm) diam (or smaller) No. 28 MSG (or heavier), or nom 20 in. (508 mm) diam (or smaller) No. 22 MSG (or heavier) steel vent duct to be installed either concentrically or eccentrically within the firestop system (see table below). The annular space between duct and periphery of opening shall be min 0 in.

(point contact) to max value shown in table below. Duct to be rigidly supported on both sides of wall assembly.

3. Packing Material — (not shown). Nom 1 in. (25 mm) foam backer rod firmly packed into the opening as a permanent form in 2 hr fire-rated wall assemblies to prevent leakage of fill material during installation. Packing material to be recessed from both surfaces of wall to accommodate the required thickness of fill material.

3. Fill, Void or Cavity Materials* — Sealant — Min 5/8 in. (16 mm) thickness of fill material applied within annulus, flush with both surfaces of wall. At the point contact location between through penetrant and gypsum board, a min 3/8 in. (10 mm) diam bead of fill material shall be applied at the gypsum board/through penetrant interface on both surfaces of wall.

Max Diam of Through Opening In. (mm)	Max Duct Diam In. (mm)	Min Duct Thickness MSG	Annular Space In. (mm)	Sealant
5 (127)	4 (102)	30	0 to 7/8 (0 to 22)	HydroFlame 200
7 (178)	6 (152)	28	0 to 1 (0 to 25)	HydroFlame 100
22 (559)	20 (508)	22	0 to 2 (0 to 51)	HydroFlame 100

RELIANCE WORLDWIDE CORPORATION DBA HOLDRITE HYDROFLAME — HydroFlame 100, HydroFlame 200

*** Indicates such products shall bear the UL or cUL Certification Mark for jurisdictions employing the UL or cUL Certification (such as Canada), respectively.**

Last Updated on 2019-02-13

Design/System/Construction/Assembly Usage Disclaimer

- Authorities Having Jurisdiction should be consulted in all cases as to the particular requirements covering the installation and use of UL Certified products, equipment, system, devices, and materials.
- Authorities Having Jurisdiction should be consulted before construction.
- Fire resistance assemblies and products are developed by the design submitter and have been investigated by UL for compliance with applicable requirements. The published information cannot always address every construction nuance encountered in the field.
- When field issues arise, it is recommended the first contact for assistance be the technical service staff provided by the product manufacturer noted for the design. Users of fire resistance assemblies are advised to consult the general Guide Information for each product category and

each group of assemblies. The Guide Information includes specifics concerning alternate materials and alternate methods of construction.

- Only products which bear UL's Mark are considered Certified.

The appearance of a company's name or product in this database does not in itself assure that products so identified have been manufactured under UL's Follow-Up Service. Only those products bearing the UL Mark should be considered to be Certified and covered under UL's Follow-Up Service. Always look for the Mark on the product.

UL permits the reproduction of the material contained in the Online Certification Directory subject to the following conditions: 1. The Guide Information, Assemblies, Constructions, Designs, Systems, and/or Certifications (files) must be presented in their entirety and in a non-misleading manner, without any manipulation of the data (or drawings). 2. The statement "Reprinted from the Online Certifications Directory with permission from UL" must appear adjacent to the extracted material. In addition, the reprinted material must include a copyright notice in the following format: "© 2019 UL LLC".

UL and the UL logo are trademarks of UL LLC © 2019 All Rights Reserved.